

CYANOBACTERIAL LIPOPOLYSACCHARIDES AND HUMAN HEALTH – A REVIEW

Ian Stewart^{1,2,3§}, Philip J. Schluter⁴, Glen R. Shaw^{1,3,5}

¹: National Research Centre for Environmental Toxicology, University of Queensland, 39 Kessels Road, COOPERS PLAINS, QLD 4108, Australia

²: School of Population Health, University of Queensland, Herston Road, HERSTON, QLD 4006, Australia

³: Cooperative Research Centre for Water Quality and Treatment, PMB 3, SALISBURY, SA 5108, Australia

⁴: Faculty of Health and Environmental Sciences, Auckland University of Technology, Private Bag 92006, AUCKLAND 1020, New Zealand

⁵: School of Public Health, Griffith University, University Drive, Meadowbrook, QLD 4131, Australia

§Corresponding author

Email addresses:

IS: i.stewart@uq.edu.au

PJS: philip.schluter@aut.ac.nz

GRS: g.shaw@griffith.edu.au

Abstract

Cyanobacterial lipopolysaccharide/s (LPS) are frequently cited in the cyanobacteria literature as toxins responsible for a variety of health effects in humans, from skin rashes to gastrointestinal, respiratory and allergic reactions. The attribution of toxic properties to cyanobacterial LPS dates from the 1970s, when it was thought that lipid A, the toxic moiety of LPS, was structurally and functionally conserved across all Gram-negative bacteria. However, more recent research has shown that this is not the case, and lipid A structures are now known to be very different, expressing properties ranging from LPS agonists, through weak endotoxicity to LPS antagonists. Although cyanobacterial LPS is widely cited as a putative toxin, most of the small number of formal research reports describe cyanobacterial LPS as weakly toxic compared to LPS from Enterobacteriaceae.

In order to place the biological activity of cyanobacterial LPS in the context of the much more widely studied LPS of Gram-negative bacteria, particularly *Escherichia coli* and *Salmonella* spp, relevant aspects of the broader immunology, microbiology and structural biochemistry literature will be reviewed.

There is a danger that what was initially speculation about cyanobacterial LPS may evolve into orthodoxy without basis in research findings. No cyanobacterial lipid A structures have been described and published to date, so a recommendation is made that cyanobacteriologists should not continue to attribute such a diverse range of clinical symptoms to cyanobacterial LPS without research confirmation. Indeed, many of the symptoms ascribed to cyanobacterial LPS only seem to appear in the

cyanobacteria literature, and were not found in the literature describing toxic effects of the much more widely studied heterotrophic bacterial LPS.

Introduction

Cyanobacterial LPS is attributed with a range of pathological effects in humans, from gastro-intestinal illness, cutaneous signs and symptoms, allergy, respiratory disease, headache and fever. This review will present the studies of cyanobacterial LPS, and will attempt to place the knowledge of these products within the broader understanding of LPS from Gram-negative heterotrophic bacteria. The paper will present an overview of the mechanisms of toxicity of Gram-negative bacterial LPS, discussing the history of its discovery and the present perception of its pathogenicity.

Cyanobacterial LPS and symptoms in humans

Table 1 lists some of the signs and symptoms reportedly associated with exposure to cyanobacterial LPS, and references that imply particular symptoms or symptom groups are explained by such exposures. Table 1 does not present an exhaustive list of citations implicating cyanobacterial LPS with human illness. Many such references are found in review articles, and the table does not include citations which discuss cyanobacterial LPS in the context of cyanobacterial toxins without linking them to specific illnesses – e.g. “Cyanobacterial toxins are of three main types: lipopolysaccharide endotoxins, hepatotoxins, and neurotoxins.” [1]; “Potential irritant; affects any exposed tissue” [2, 3]; “(LPS) are responsible for the irritant nature of

cyanobacterial material” [4]; and “...toxigants such as...lipopolysaccharide endotoxins...affect any exposed tissue...” [5].

Several authors note that the health implications of cyanobacterial LPS are poorly understood and the topic requires more research [6-15]. Only one reference was found in the cyanobacteria literature that raises doubts about illness caused by cyanobacterial LPS: Carmichael [16] suggests that the relationship between ingested LPS and illness in an immunologically competent population is debatable, there being little evidence that people with a normal LPS-containing gut flora would be affected by LPS from water supplies.

The relationship between cyanobacterial LPS and illness is discussed in language ranging from cautious: “...may be responsible...” [17], “possibly (due to) lipopolysaccharides” [15], to definitive: “dermatotoxins” [18] and “dermatotoxic lipopolysaccharides” [19, 20]. Cyanobacterial LPS has also been implicated as the cause of an outbreak of pyrogenic reactions in a haemodialysis clinic in 1974 [21].

The references in the literature to the association between cyanobacterial LPS and this rather diverse range of symptoms are not based on any research evidence specific to cyanobacterial LPS. As will be discussed later in this review, the few toxicological investigations that have been carried out to date are mostly limited to the end-points of lethality and the local Shwartzman reaction, in which sequential subcutaneous and intravenous injections of LPS produce a dermonecrotic lesion in rabbit skin. Rather, symptomatology attributed to contact with cyanobacterial LPS appears to be something of a default diagnosis for illnesses that are not otherwise explained by the

current knowledge of cyanobacterial exotoxins, most of which are somewhat specific to their target organ system.

The most likely explanation for the ready attribution of these illnesses to cyanobacterial LPS lies in the realisation that LPS from Gram-negative heterotrophic bacteria are implicated in significant morbidity – and mortality – so cyanobacteria, which are widely but somewhat inaccurately accepted as Gram-negative bacteria may equally be responsible for illness because they contain LPS. Codd makes such a proposition, suggesting that: “The LPS of other bacteria are associated with gastroenteritis and inflammation problems and it is thought that cyanobacterial LPS may contribute to waterborne health incidents although this possibility has not been adequately investigated” [13].

There is a risk that speculative attribution of symptoms in humans to environmental exposure to cyanobacterial LPS will continue without an appropriate and specific research foundation. This review will attempt to examine more closely the mechanisms by which LPS from Gram-negative heterotrophic bacteria is associated with morbidity, and compare and contrast cyanobacterial LPS and heterotrophic bacterial LPS.

Cyanobacteria: Gram-negative or Gram-positive?

Most references to cyanobacteria describe these organisms as Gram-negative prokaryotes [17, 22-24, 25 (p.97), 26]. Weckesser *et al* [27] state that the presence of

LPS is evidence for the Gram-negative cell wall architecture of cyanobacteria. However, Weckesser *et al* [28] reported that a strain of *Anabaena variabilis* they investigated was Gram-positive, “like other blue-green algae...”. Drews [29] also classifies cyanobacteria as Gram-positive. Golecki [30] reviewed electron microscopy studies of the cell wall architecture of various bacteria, and suggested that cyanobacteria have characteristics of both Gram-negative and Gram-positive organisms. They contain an outer membrane and LPS, which are defining characteristics of Gram-negative bacteria [31, 32], and a thick, highly cross-linked peptidoglycan layer similar to Gram-positive organisms. Jürgens & Weckesser [33] and Golecki [30] suggest that the chemical and structural organisation of the cell wall may place cyanobacteria in a separate phylogenetic category to both Gram-negative and Gram-positive bacteria, with cyanobacteria developing independently of Gram-negative and Gram-positive bacteria from a common ancestor. However, according to Margulis & Schwartz [34], electron microscopy shows that cyanobacteria have Gram-negative cell walls.

Terminology: “endotoxin” in the cyanobacteria literature

While most references to endotoxin in the cyanobacteria literature (e.g. those in Table 1) are clearly referring to LPS, i.e. cell wall structural components, this is not always the case. Several authors discuss “endotoxins” when they were obviously describing the toxic properties of microcystins [35-41]. Kay [42] refers to aphantoxin (now known as saxitoxins) from *Aphanizomenon flos-aquae* as an “alkaloid endotoxin”. Gentile & Maloney [43] also labelled what were presumably saxitoxins as an

endotoxin. In recent years cyanobacterial hepatotoxins and neurotoxins are still being described as endotoxins [44, 45]. This misunderstanding of the nomenclature is also seen in biotoxin research fields outside of cyanobacteria, with brevetoxins described as endotoxins [46]. Immunologists clearly understand endotoxins to refer only to LPS of Gram-negative bacteria. The reader's attention is drawn to this distinction, as throughout this review "endotoxin" and "LPS" are used more or less interchangeably, whereas other cyanobacterial toxins such as microcystins, cylindrospermopsin, saxitoxins and anatoxin-a, when discussed in aggregate are referred to as "exotoxins". The history of the term "endotoxin" and its current use are discussed in the following section.

Gram-negative bacterial LPS: Introduction and its discovery

LPS from many bacterial species will initiate acute inflammatory responses in mammals that are typical of the host reaction to tissue injury or infection [47]. LPS can induce a large and diverse range of effects, ranging from pyrexia to Gram-negative septic shock, which manifests as a complex and dramatic syndrome involving fever, leucopenia, hypotension, cardiopulmonary dysfunction, disseminated intravascular coagulation and multi-system failure [48, 49].

The history of the understanding of LPS starts in the late nineteenth century, when Richard Pfeiffer used heat-inactivated lysates of *Vibrio cholerae* to provoke pathophysiological effects in guinea pigs [48]. Pfeiffer named the heat-stable and cell-associated toxic substance "endotoxin", to distinguish it from the heat-labile and

proteinaceous exotoxins, which were known to be secreted by replicating bacteria [48-51]. Initial analyses of endotoxin revealed that it contained polysaccharide and lipid, and was thus named lipopolysaccharide. The terms “endotoxin” and “lipopolysaccharide” are widely used by workers in a variety of biomedical fields as synonyms to describe the same molecule (many references, e.g. [48, 51-57] including the field of cyanobacteria research: “lipopolysaccharide endotoxins” [20, 58-60]. However, some authors have suggested that LPS should refer to the purified molecule, whereas endotoxin more appropriately describes macromolecular complexes of LPS, protein, phospholipid and nucleic acids [49, 50, 61].

The study of LPS, which was largely concerned with investigating fever, progressed in the late 1940s with the discovery of endogenous pyrogens [49]. Since then, the field of cytokine biology has made enormous strides. It is now understood that the pathological effects of LPS are indirect, i.e. LPS acts by initiating a cascade of host-mediated responses: initially monocytes and macrophages are stimulated, and then neutrophils and platelets congregate in microcapillaries, causing vascular injury. Inflammatory cells release a range of endogenous mediators, including arachidonic acid metabolites, platelet-activating factor, cytokines such as interleukin-1 (IL-1), IL-6 and tumour necrosis factor-alpha (TNF- α), nitric oxide, toxic O₂ metabolites, vasoactive amines, proteases and products of the complement and coagulation cascades. There are many reviews in the literature on cytokines and LPS - some recent examples are: [47-49, 51, 55, 56, 62, 63]. Cytokine-mediated responses are extremely complex: cytokines are pleiotropic, i.e. a single type of cytokine affects several different types of cell. Cytokines have autocrine effects, i.e. they can stimulate the cells that secrete them to produce more cytokines, and paracrine effects – stimulating

other cells to produce different cytokines [64]. Signs and symptoms in human volunteers after administration of endotoxin are: fever, rigors, and influenza-like symptoms of fatigue, headache, nausea, myalgia, arthralgia, drowsiness, mild amnesia and diarrhoea [47, 61, 65, 66].

From the discovery that LPS-associated pathology results from the stimulation of host cell responses came the realisation that LPS binds to specific receptors in order to elicit the release of cytokines and other inflammatory mediators [63]. Several membrane-bound and soluble proteins have been shown to bind LPS; the most important appear to be CD14 and LPS-binding protein (LBP) [48, 51, 52, 55, 63, 67]. The Toll-like receptor (TLR) family are a recently discovered group of transmembrane receptors that are fundamental in signalling innate immune responses to conserved microbial structures, and they are also involved in the recognition of some endogenous ligands. TLR4 is instrumental in signalling LPS from many Gram-negative bacteria, and TLR2 is involved in the recognition of some unusual LPS. There is a considerable and rapidly expanding body of literature on the TLR family; one of the most comprehensive reviews is by Takeda *et al* [68]. A review by Janeway and Medzhitov [69] is an excellent introduction to TLRs, and places the activity of these receptors in the broader context of innate immunity.

Knowledge of the role of specific receptors in mammalian hosts has led to the demonstration that LPS itself is non-toxic. Schnaitman notes that “LPS itself is not toxic” [70] and Henderson *et al* describe LPS as “relatively inactive” and observe that several host proteins are necessary for LPS to display full agonist potency [49]. CD14-deficient cell lines such as Chinese hamster ovary are unresponsive to LPS at high

doses, and cell lines that show poor LPS activation can be converted to show high activation when transfected with the CD14 gene [70]. LPS-unresponsive mouse strains and cytokine knockout strains also serve to reinforce the concept that LPS is not directly toxic, and the pathophysiology associated with Gram-negative LPS results from host-mediated factors [67, 71-76].

LPS structure – similarities and differences across Gram-negative bacteria

LPS from different Gram-negative species apparently share common features in their basic architecture. A structure consisting of four covalently linked segments – a surface carbohydrate polymer (O-specific chain), a core oligosaccharide featuring an outer and inner region, and an acylated glycolipid (termed lipid A) is seen in such ecologically diverse bacteria as *Salmonella*, *Pseudomonas*, *Vibrio* and *Rhizobium* [77]. The O-specific chain shows the most diversity, and is the basis for serological specificity [48], while lipid A, which anchors the LPS molecule in the Gram-negative outer membrane, is the most conserved biochemical structure across different bacterial species [71] (See Figure 1). There is unequivocal acceptance that the lipid A moiety is the biologically active component of LPS [78]. This was confirmed by the observations that LPS from polysaccharide-deficient mutant strains were equally as bioactive as parent LPS [71, 79], and chemically synthesised *Escherichia coli* lipid A exhibits identical activity to natural *E. coli* lipid A [80].

Are all LPS equal in terms of their host-mediated responses?

Although the basic structure of lipid A is seen in phylogenetically diverse Gram-negative bacteria, variations in the nature and location of acyl groups or alterations in the hydrophilic backbone can result in partial or total loss of biological activity [48, 51, 81, 82]. An example is seen in the case of some purple non-sulfur bacteria, which could be considered to be somewhat more representative of cyanobacteria when it comes to drawing comparisons on the biological activity of LPS. Purple non-sulfur bacteria, being photosynthetic, are Gram-negative bacteria that occupy a similar ecological niche to that of cyanobacteria, and therefore have growth and reproductive strategies that much more closely resemble cyanobacteria than the heterotrophic, gut-dwelling *E. coli* and *Salmonella*. Lipid A from *Rhodobacter sphaeroides* and *Rhodobacter capsulatus* is not only inactive, but is an antagonist of Enterobacteriaceae LPS-induced cell activation [48, 49, 52, 83]. *R. sphaeroides* and *R. capsulatus* lipid A differs from that of *Escherichia coli* in several respects, all relating to the acylation pattern; the lack of endotoxic activity in *R. sphaeroides* and *R. capsulatus* appears to be attributable to the presence of five rather than six fatty acid groups, and the shorter chain lengths (C_{10} in *R. sphaeroides* and *R. capsulatus* compared with C_{14} in *E. coli*) in two ester-linked fatty acids [83]. Lipid A from *R. sphaeroides* and *R. capsulatus* is of pharmacological interest because of their LPS-antagonist properties; these lipid A structures and some synthetic derivatives have been shown to be potent LPS antagonists *in vitro* and to protect against LPS-induced morbidity and mortality in animal models [49, 77, 84]. Competitive inhibition of

biologically active LPS by LPS antagonists further illuminates the requirement for host cell receptor sites in mediating the responses to LPS [52]. Other purple non-sulfur bacteria, e.g. *Rhodopseudomonas viridis* and *Rhodopseudomonas palustris* are also reported to lack endotoxic activity [27, 83], but the lipid A from another purple non-sulfur bacterium, *Rubrivivax gelatinosus*, is reportedly associated with high lethality in mice – at similar doses that cause lethality in *Salmonella* – and high pyrogenicity in rabbits [27, 83]. The high endotoxicity of *R. gelatinosus* is apparently due to the presence of six fatty acid groups in the lipid A structure [83, 85].

Bacteroides spp, which are common gut and periodontal commensals, have low endotoxic activity compared to that of *Salmonella*, with a greater than 500-fold higher mouse LD₅₀ and 100 to 1,000-fold reduced ability to stimulate production of IL-1 in monocyte cultures [86, 87]. *Bacteroides fragilis* LPS inhibits *E. coli* LPS-induced endothelial adhesiveness for polymorphonuclear leucocytes, although *B. fragilis* LPS is reported to be directly toxic to endothelial cell cultures at high concentrations [52]. In a study of cytokine induction in whole blood, Frieling *et al* [88] showed that *B. fragilis* stimulated IL-1 β , IL-6 and IL-1ra at levels comparable to Gram-positive bacteria, where 100 to 1,000-fold more organisms are required to produce similar concentrations of cytokines than with common pathogenic Gram-negative bacteria. Wilson *et al* [89] suggest that *B. fragilis* may be such a weak cytokine inducer because, being a dominant organism in normal gut flora, it has evolved mechanisms to downregulate the synthesis of inflammatory cytokines in order to optimise their niche in the host gut. *B. fragilis* has five fatty acyl groups in the lipid A moiety, and other structural differences to *Salmonella* and *E. coli* LPS, such as a monophosphorylated disaccharide backbone and longer fatty acyl chains [90].

Some pathogenic bacteria have LPS which reflects the highly specific niches they inhabit: enteric Gram-negative bacteria have long, hydrophilic and neutral O-specific polysaccharide chains which protect the organism from solubilisation by bile acids and intestinal enzymes, whereas organisms that colonise the mucous membranes of the respiratory and genital tracts have outer membrane surfaces that are hydrophobic and can be solubilized by bile [91, 92]. Gram-negative bacteria such as *Neisseria*, *Haemophilus* and *Bordetella* have developed unique surface glycolipids lacking O-antigens, which some workers call lipooligosaccharides [91, 92].

The presence of one or more secondary acyl chains appears to be essential for lipid A to stimulate some endotoxic reactions [81, 87]. One of the final stages of Enterobacteriaceae lipid A biosynthesis is the formation of acyloxyacyl groups, so-called secondary fatty acids [93]. A leucocyte enzyme, acyloxyacyl hydrolase, selectively removes these secondary fatty acyl groups, without releasing the 3-hydroxy acyl chains that substitute the lipid A disaccharide backbone [81, 94]. Deacylated LPS from *E. coli*, *Salmonella typhimurium*, *Haemophilus influenzae* and *Neisseria meningitidis* were shown to have reduced activities in a series of tests relating to endotoxic potential, in some cases by greater than two orders of magnitude, and deacylated *Neisseria* LPS demonstrated some antagonistic activity towards *Neisseria* and *Salmonella* LPS [81, 94, 95].

The lipid A analog, compound 406, which lacks the two secondary fatty acids of *E. coli* lipid A, is unable to induce cytokines in human cells [48, 51, 74]. Rietschel *et al* [51] propose that endotoxic capacity resides in the spatial conformation of lipid A, in

that biologically inactive lipid A (e.g. *R. capsulatus*) conforms to lamellar structures, whereas endotoxic lipid A adopts exclusively cubic or hexagonal structures.

Netea *et al* [96] suggest that the historical assumption that LPS from different Gram-negative bacteria possess similar biological effects is incorrect, and that differences between LPS across species are the rule rather than the exception. The authors discuss structure-function relationships between LPS and the Toll-like receptors (TLRs), which are integral in LPS-mediated signalling, suggesting that differences in the three-dimensional conformation of LPS molecules translate into differences in TLR signalling of proinflammatory cytokines. In their reviews of the supramolecular structure and phase transition states of LPS and lipid A, Seydel and Brandenburg [97] and Seydel *et al* [54] suggest that endotoxic activity is related to the three-dimensional conformation of LPS and the multimeric aggregates they form. The conformation of LPS or lipid A within such aggregates is not constant, but a reversible phase transition occurs, which is temperature-dependent and related to the length and degree of saturation of the acyl chains and other physiological conditions.

More recent work by Seydel and collaborators has led to the realisation that the biological activity of specific lipid A structures can be determined by an understanding of its supramolecular structure, which is a function of the monomeric conformation, which in turn is largely determined by the primary molecular structure [82, 98, 99]. The presence of sufficient negative charges on the disaccharide backbone – mainly, but not necessarily, two phosphate groups – has an important influence on lipid A molecular conformation and the binding capacity to serum proteins such as LBP [82, 100]. A high negative charge density is reported to

be an essential requirement for agonistic and antagonistic properties; complete or partial substitution of negative charges can result in the loss of all biological activity [82, 101]. Seydel's team now suggest that a general principle can be applied regarding the molecular conformation of lipid A structures and their biological activity: lipid A structures that adopt conical/concave shapes have hexagonal or cubic supramolecular aggregate structures and express high endotoxic potential, whereas lipid A structures that adopt cylindrical conformations have lamellar aggregates and are either inactive or LPS antagonists [98]. Thus lipid A of the photosynthetic bacterium *R. gelatinosus*, which has high endotoxic activity [27, 83], was seen to adopt hexagonal aggregate structures, whereas the lipid A of other non-endotoxic photosynthetic bacteria adopt cylindrical shapes and lamellar aggregate structures [98, 99, 102]. Lipid A from *Chromobacterium violaceum* forms a cylindrical geometry and is reportedly three orders of magnitude less active than *E. coli* lipid A [103]. Ulmer *et al* [104] also found that a synthetic lipid A structure based on *C. violaceum* lipid A had markedly lower cytokine-inducing capacity than an *E. coli*-based synthetic lipid A. These findings are in contrast to some other reports, which describe *C. violaceum* lipid A as having a high agonist activity [51, 74]. Of interest is the observation that the primary lipid A structures of *C. violaceum* and *R. gelatinosus* are very similar (bisphosphorylated diglucosamine backbone, six symmetrically distributed acyl chains differing only in the length of the two acyloxyacyl groups: C=12 in *C. violaceum* and C=10 for *R. gelatinosus*) [83]. Yet *C. violaceum* lipid A is an LPS antagonist, whereas *R. gelatinosus* lipid A expresses high agonist activity. Seydel *et al* [103] suggest that the chemical structures of these two lipid A's may need to be re-examined. Lipid A of *Campylobacter jejuni*, which has low endotoxic potential, shows a very slight

tendency to adopt a conical/concave shape, whereas the lipid A of *E. coli* clearly adopts a conical/concave form [98, 105].

As a result of these studies, the ability of a lipid A monomer to adopt a conical shape (the so-called endotoxic conformation) has been described as a prerequisite for endotoxicity [99]. Seydel *et al* [103] suggest that when lipid A molecules are intercalated into target cell membranes, only lipid A which forms a conical shape – where the cross-sectional area of the hydrophilic backbone is smaller than the cross section of the hydrophobic acyl groups – can exert a mechanical stress on signalling proteins. LPS with a lipid A moiety which assumes a cylindrical shape – cross-sectional areas of the hydrophobic and hydrophilic components being roughly equal – will occupy the binding site but be unable to activate signalling proteins, thus acting as an LPS antagonist [101, 103]. The number and distribution of acyl chains has been shown to affect the tilt angle of the disaccharide backbone with respect to the target cell membrane; the orientation of the backbone sugars appears to correlate with the endotoxic potential of the LPS. The lipid A molecular shape and the tilt angle of the backbone sugars are reported to be the complete determinants of endotoxic activity [101, 103].

The discussion above has contrasted the endotoxic potential of lipid A structures from the most widely studied forms, those of the Enterobacteriaceae, with some unusual lipid A's from photosynthetic bacteria and synthetic lipid A analogs. The reason that cyanobacterial LPS has not been discussed here is simply that the required research has not been done as yet. No cyanobacterial lipid A structures have been published, therefore no inferences can be deduced as to their likely endotoxic potential, or lack of

it. But with the knowledge that endotoxic potential can vary in the most fundamental way across Gram-negative bacteria, from agonistic to weakly active to inactive to antagonistic, it should be incumbent on the cyanobacteria research community to cease attributing biological activity and clinical symptoms to cyanobacterial LPS without research evidence. Cyanobacteria may not be typical Gram-negative organisms because of their unusual cell wall architecture, and cyanobacteria will have experienced very different selection pressures to gut-dwelling Gram-negative bacteria, which may be reflected in different lipid A structures.

LPS and infection

Much research into LPS and lipid A has understandably concentrated on the severe, life-threatening host responses to circulating LPS that constitute Gram-negative septicaemia and septic shock. Many experimental models have utilised either *in vitro* studies of isolated cell lines or animal and human studies where LPS is exposed to the circulation by parenteral injection.

The matter of the degree to which cyanobacterial LPS/lipid A can stimulate mammalian cytokine networks under experimental conditions, which remains largely unanswered, is only one aspect in the understanding of cyanobacterial LPS and the gastro-intestinal, respiratory and cutaneous illnesses which have been attributed to contact with it. The other side of the story that needs to be considered is the mechanism by which cyanobacterial LPS might (and might not) stimulate endotoxic

responses by the various exposure routes: ingestion, inhalation and contact. The following discussion will briefly review the association between acute gastrointestinal illness and Gram-negative bacterial LPS. Cutaneous responses to LPS will be briefly discussed.

Terminology: infection, pathogen

Infectious diseases are characterised by several discrete steps: bacterial adhesion to the host, colonisation within or on the host, and evasion of host defences [31, 49]. The only references in the literature that describe cyanobacteria as invasive, infectious organisms were from two authors:

- Rank [106-108] put forward the hypothesis that a chronic, low-virulence infestation by cyanobacteria growing heterotrophically may explain the aetiology of arteriosclerosis in humans and homeothermic animals. The author bases his theory on ecological data, examining the geographical, demographic and historical distribution of the disease. Routes of infection are posited to be ingestion of unfermented milk, public water supplies drawn from surface waters as distinct from groundwater [107, 108], and earth-contaminated food and other objects [106]. The author also critiques the three theories of the pathogenesis of arteriosclerosis that were current at the time (response-to-injury, lipid hypothesis, and monoclonal hypothesis) and suggests laboratory studies to replicate and study the disease. Such studies do not subsequently appear in the literature, and no further reference to the cyanobacterial infection hypothesis can be found.

- Ahluwalia *et al* [109] and Ahluwalia [110, 111] posited the theory that *Microcystis aeruginosa* is the causative organism of the mostly tropical, water-exposure-related invasive disease rhinosporidiosis. However, this theory has been disputed; convincing and probably conclusive evidence appears to place the eukaryotic protist *Rhinosporidium seeberi* as the causative organism (see Author's reply to Ahluwalia [111]).

Most public health workers would presumably place cyanobacteria-related illnesses in the context of environmental exposures, as distinct from familiar diseases due to communicable infectious bacteria, which, in many cases feature transmissible illnesses, secondary to the original reservoir of infection. Cyanobacteria-related illness is viewed as intoxication, rather than infection, usually on the basis of a sudden onset of symptoms occurring soon after exposure (i.e. without an incubation period), and lack of secondary cases [112]. Giesecke [113] defines infectious disease as “all diseases caused by micro-organisms”, with sub-definitions of communicable and transmissible disease (communicable disease: capable of being transmitted from an infected individual to another person, directly or indirectly; transmissible disease: able to be transmitted from one individual to another by ‘unnatural’ routes). Whether cyanobacteriologists would embrace that definition of infectious disease is debatable, but most would agree that cyanobacteria-related diseases are neither communicable nor transmissible. Exotoxin-producing cyanobacteria certainly fit the dictionary definition of pathogenic (i.e. disease-causing) organisms; the reader's attention is drawn to the distinction between infectious (implying colonisation and evasion of host defences) Gram-negative bacteria and non-infectious cyanobacteria in the following discussions on LPS and G-I and dermal illnesses.

Mechanisms of vomiting and its relationship to LPS activity

Nausea and vomiting are normal physiological responses to the ingestion of toxic substances; they are essential defences because they are the end result of the actions of sensorimotor systems that operate to identify and rapidly expel hazardous substances from the upper G-I tract [114-116]. The two main sensory systems that direct the emetic response are local, associated with the gut mucosa (pre-absorptive response), and central, specifically the chemoreceptive trigger zone of the area postrema, located in the dorsal surface of the medulla oblongata (post-absorptive response) [117-119].

Stimulation of chemoreceptors in the stomach, jejunum and ileum by irritant chemicals such as hypertonic saline, copper sulfate or mustard, or by bacterial enterotoxins, leads to the activation of vagal sensory afferent nerves to the brain.

Vagal efferent processing through the enteric nervous system stimulates enteric motor neurons to effect emesis [114, 116, 118, 119]. Emetic chemoreceptors are also found in the vascular system; activation of these chemoreceptors will also initiate nausea and vomiting [114]. Endogenous mediators of emesis such as dopamine, acetylcholine and enkephalin are reported [114]. Prostaglandins have well-known emetic actions [120].

Circulating *E. coli* LPS is a potent emetic stimulant. In a series of experiments using piglets, Girod *et al* [121] showed that parenteral administration of LPS provoked vomiting (as well as fever, rigors, purpura, diarrhoea and drowsiness). The authors suggested that LPS stimulates vomiting by means of cytokine-induced prostaglandins

and other endogenous mediators acting both centrally and on vagal afferents. Other animal studies have demonstrated the emetic action of LPS [122].

The area postrema is reported to be the primary sensory area involved in nausea as well as vomiting, although nausea is accompanied by autonomic excitation, whereas vomiting is a somatic process independent of the autonomic nervous system [117, 120]. Presumably LPS-stimulated endogenous mediators are associated with symptoms of nausea, which is reported in several studies and reviews of intravenous exposure to LPS in human volunteers [47, 61, 65, 66].

To investigate vomiting associated with exposure to cyanobacteria, the appropriate research efforts should determine whether cyanobacterial LPS is capable of stimulating gut chemoreceptors, or if cyanobacterial LPS can gain access to the circulation and stimulate nausea and vomiting centrally. Another point of interest should be directed towards the cyanobacterial exotoxins, as to their capacity to stimulate either gut mucosal chemoreceptors, vascular emetic chemoreceptors, or by endogenous mediators. Bacterial exotoxins such as staphylococcal enterotoxins (SEs) are known to stimulate emesis via gut chemoreceptors [115, 116, 123]. Worthy of note is that experimental induction of LPS-related emesis is achieved by intravenous or intraperitoneal routes [121-126], whereas SEs readily elicit vomiting when administered intragastrically [123, 127]. Also of interest with respect to cyanobacteria-related G-I illness are some similarities of clinical symptoms in the case of staphylococcal food poisoning: enteritis due to ingestion of SEs is characterised by rapid onset (1-4 hours) of vomiting \pm nausea and diarrhoea, abdominal cramping and

dizziness [123, 128]. Staphylococcal food poisoning is an intoxication, not an infectious process [128].

Diarrhoea and LPS

One inference that can be drawn from the references that posit cyanobacterial LPS as the cause of G-I illnesses (see Table 1) is that these symptoms are not necessarily related to exposure to any of the known cyanobacterial exotoxins, the assumption being that exposure to – and presumably illness caused by – cyanobacterial LPS can occur with or without concurrent exposure to exotoxins (i.e. from non-toxic strains or species, or non-production of exotoxins at the time of exposure). However, several questions need to be answered if LPS is the sole presumptive “G-I-toxin”. A hypothesis is needed for the mechanism of cyanobacterial LPS, in the absence of other virulence factors, to initiate diarrhoea by the oral exposure route. Another explanation for cyanobacterial LPS-related diarrhoea is that the alteration in gut membrane permeability may be related to a cytokine cascade generated by circulating cyanobacterial LPS, but again, a hypothesis is needed to explain the exposure route for the LPS to overcome innate immune intestinal defences in order to gain access to the circulation.

Some observations on the behaviour of Gram-negative bacterial LPS in the gut serve to cast doubt on the suspicions that cyanobacterial LPS alone is responsible for initiating acute gastro-intestinal illness in humans by the oral route:

- **Commensal gut flora:** The human intestinal tract houses an enormous population of bacteria, many of which are Gram-negative. The Enterobacteriaceae are found in normal faecal flora at some 10^8 - 10^9 per gram [129]. The number of microbes in the gut lumen exceeds the number of eukaryotic cells in the human body by an order of magnitude [49, 130], an observation that may lead some to unkindly suggest that the principal reason for human existence is to serve as bags for the housing and transport of bacteria. Nanthakumar *et al* [131] note that mature enterocytes are 100 to 1,000 times less sensitive to LPS than neutrophils and hepatocytes, which is not surprising since they are exposed to Gram-negative bacteria and their endotoxins since birth when the gut is colonised.
- **Non-virulent strains:** Most Gram-negative organisms are non-pathogenic. Pathogenicity involves a complex interaction between host-related and specific microbial virulence factors - the latter including pili, fimbriae and heat shock proteins [132, 133]. Infectious, i.e. colonising, microbes are the most common cause of diarrhoea worldwide; pathogenic strains commonly cause disease by the action of enterotoxins [134]. That virulence factors other than lipid A structures of LPS are responsible for gastro-intestinal disease is seen in the protective effects of attenuated or mutant Gram-negative bacteria when used as live oral vaccines against pathogenic strains [132, 135-137]. Some *E. coli* strains are used as probiotics for the treatment of gastrointestinal disease and infection prophylaxis in neonates [138].
- **Anecdotal reports of consumption of non-hazardous cyanobacteria:** Heaney [39] reports observations of cattle seen drinking from two Irish lakes affected by

thick scums of *Anabaena flos-aquae* and *Aphanizomenon flos-aquae* without ill effect. Author IS can add a similar observation: during recruitment for an epidemiology study [139] at Lake Coolmunda in southern Queensland, a frank *Microcystis aeruginosa* bloom was in attendance. A group of six or seven dogs were seen playing vigorously in the water, and three dogs were observed drinking from it. The owners of the animals were questioned the following day; all denied observing any adverse effects. The consumption of *Spirulina* and other cyanobacteria provides further evidence that cyanobacterial LPS cannot all be harmful. Cyanobacteria as food, medicine and livestock feed will be discussed later in this review.

Oketani *et al* [140] state that orally administered LPS is not harmful to animals, which is in stark contrast to LPS administered parenterally. Evidence for harmful effects of orally administered LPS is difficult to gather from the literature because of the overwhelming number of publications describing experimental use of LPS as an *in vitro* and *in vivo* immune stimulant. The authors of this review have been able to find two reports of *in vivo* LPS activity by the oral route: Yang *et al* [141] showed that oral administration of *E. coli* LPS enhanced the progression of hepatoma in rats treated with thioacetamide. Yoshino *et al* [142], using a mouse model of autoimmune disease, demonstrated that orally-dosed LPS exacerbated collagen-induced arthritis. These models of liver disease and autoimmunity are not applicable to the concept of acute G-I symptoms caused by cyanobacterial LPS in presumably healthy people in recreational settings and through cyanobacterial contamination of drinking water supplies. However, they highlight the importance of gut mucosal immunity. LPS and other microbial products are constantly sampled by gut-associated lymphoid tissues,

which contain the largest assemblage of immunocompetent cells in the body [130]. Translocation of small amounts of LPS from the gut lumen across the epithelium and into the portal circulation is an important immune-stimulating process, with Kupffer cells in the liver playing an important role in clearance of LPS from the circulation [130]. LPS and other bacterial products from the normal gut flora can be a source of infection and sepsis when the integrity of the gut mucosa is disrupted. This occurs in a variety of disease states, including hypovolaemic shock, burn injury, trauma, acute liver failure, pancreatitis, cirrhosis and inflammatory bowel disease [130].

Roth *et al* [143] suggest that endogenous (i.e. gut-derived) LPS is a potent synergist of the toxicity of a range of structurally and functionally unrelated hepatotoxic xenobiotic agents. The authors put the proposition that hepatotoxicity associated with some chemicals is indirectly caused by primary damage to the intestinal tract, which allows increased translocation of bacterial LPS into the portal circulation. The liver is then exposed to harmful levels of LPS, and the ensuing liver injury resembles that caused by large doses of LPS: changes in sinusoidal and parenchymal cells, neutrophil and platelet accumulation in sinusoids, then multifocal hepatocellular degeneration and necrosis. Yee *et al* [144] showed that co-administration of individually non-toxic doses of LPS and the alkaloid phytotoxin monocrotaline produced significant liver injury, characterised by midzonal and centrilobular apoptotic and necrotic changes, coagulation and congestion, and loss of sinusoidal architecture. Ganey & Roth [145] propose that the activation and increased expression of various soluble mediators, signalling molecules and cellular processes are crucial events in the augmentation of xenobiotic toxicity by bacterial LPS, and that the mechanisms of toxicity are complex and variable.

Purified microcystins as well as microcystin-producing and cylindrospermopsin-producing cyanobacteria have been shown in accidental poisonings and through *in vivo* and *in vitro* experimental work to damage the gastrointestinal tract [37, 146-152]. The possibility should be considered that cyanotoxins and LPS (from cyanobacteria and/or from gut-dwelling heterotrophic bacteria) may cross a disrupted gut mucosal barrier and enhance the pathological effects of cyanobacterial exotoxins.

LPS and cutaneous reactions

As with LPS and oral exposure, searching bibliographic databases for evidence of LPS/endotoxin as the primary cause of acute clinical dermatoses is a difficult task, again because of the many citations of *in vitro* immunology work using LPS to investigate various dermal cell processes. As a starting point, dermatology textbooks were perused, yet only one of a dozen or so standard texts made any reference to either LPS or endotoxin: Rietschel & Fowler [153] describe a single case report of a hospital worker who suffered dyshidrosis (a vesicular or vesicopustular eruption on the palms of the hands), which was linked to endotoxin in latex gloves. Various dermatoses are clearly associated with either superficial or systemic infection by many Gram-negative organisms, most notably *Pseudomonas aeruginosa* [154]. However, it is unreasonable to compare mechanisms of cutaneous disease from colonising Gram-negative bacteria to those due to cyanobacteria solely on the basis that both organisms contain LPS.

Cyanobacterial LPS

Literature searches using PubMed and Web of Science with the search terms (cyanobacteria* OR blue green alga*) AND (LPS OR endotoxin) revealed 17 publications that describe the extraction ± purification of cyanobacterial LPS. The Westphal hot phenol/water method was used in 15 of these studies (described in [155]). Jürgens *et al* [156] used a sucrose density centrifugation and Triton X-100 extraction, and Papageorgiou *et al* [157] compared the phenol/water method with novel extraction methods. Raziuddin *et al* [158] used chloroform and acetic acid extraction to isolate lipid A from their LPS extract. Table 2 lists the studies in which cyanobacterial LPS were tested for lethality in mice. All doses were reported in the original papers in terms of dose per mouse; these doses have been converted to mg/kg body weight for comparison purposes in Table 2. An assumed weight of 20g was applied to mice for the studies in which the authors did not report the weight of their animals. Note that the study of Scholtissek *et al* [159] used galactosamine-sensitised mice, so their LPS doses are not directly comparable to those given in the other studies; a similar situation applies with the study of Katz *et al* [160], where adrenalectomised mice were used. Adrenalectomy sensitises mice by three orders of magnitude to the lethal effects of LPS [161, 162]. By way of comparison, some examples of reported lethal concentrations of Enterobacteriaceae LPS are: 5-20mg/kg [163], 6mg/kg [164] and 24mg/kg [162] (LD₅₀ concentrations in various strains of LPS-sensitive mice; assumed weight of mice = 20g) to LD₈₀ concentrations of 10-23 mg/kg [165].

In addition to lethality, various other toxicity endpoints were examined in some of the studies listed in Table 2 and others. Buttke & Ingram [166], Keleti *et al* [167] and Keleti & Sykora [168] investigated the local Shwartzman reaction, which is a dermonecrotic lesion elicited in rabbits by subcutaneous preparative and intravenous provocation injections. Positive Shwartzman reactions were generated by *Agmenellum quadruplicatum* LPS, *Schizothrix calcicola* LPS and *Anabaena flos-aquae* LPS, but not by *Oscillatoria tenuis* LPS [166-168]. These results should be regarded as qualitative, as no reports were made of quantitative measurements of lesions, which can be done by various methods [169, 170]. However, the local Shwartzman response to *A. quadruplicatum* LPS led the study authors to describe *Agmenellum* LPS as “a less effective endotoxin than *Salmonella* LPS” [166]. The Shwartzman reaction to *A. flos-aquae* LPS was reportedly “weakly positive” [168]. Keleti & Sykora [168] also used a rabbit isolated ileal loop assay, which did not show any positive findings from the three cyanobacterial LPS isolates injected. Weise *et al* [171] tested *A. nidulans* LPS for pyrogenicity in rabbits, reporting a tenfold lower response than that seen from *E. coli* LPS. Schmidt *et al* [172] also tested the LPS from two *Synechococcus* strains for pyrogenicity, with maximum increases in rabbit body temperature of 1.5⁰C after injection of up to 1mg/kg. The authors report that these doses are some three orders of magnitude higher than those required of *Salmonella* LPS to achieve the same effect. LPS extracted and purified by author IS and also by Papageorgiou *et al* [157] were investigated for their potential to affect thermoregulation in a mouse model. LPS from several cyanobacterial isolates induced sickness behaviour and transient hypothermia at doses of 70mg/kg i.p.; similar responses in positive control animals were seen after i.p. injection of 4mg/kg *E. coli* LPS. Cyanobacterial LPS doses of 7mg/kg also

initiated transient hypothermia and sickness behaviour, although at markedly lower intensity and duration than was seen with *E. coli* LPS at 4mg/kg [155].

Most workers concluded that the cyanobacterial LPS they examined were weakly toxic when compared to the activity of positive control heterotrophic bacterial LPS. The exception was the work of Best *et al* [173], who investigated the potential of isolated cyanobacterial LPS to reduce the activity of glutathione *S*-transferases (GSTs) in Zebra fish embryos. They reported that cyanobacterial LPS reduced microsomal and soluble GSTs *in vivo* to a greater extent than LPS from *E. coli* or *Salmonella typhimurium*. The authors suggested that such reduction in GST availability may deleteriously affect the ability of organisms to detoxify microcystins, presumably through decreased utilisation of glutathione (GSH) for conjugation reactions. This would seem to be a reasonable assumption, although other interpretations of this finding are possible. While the GSH system is an essential intracellular redox buffer, preventing oxidative injury, it is also an important participant in many cellular functions, including DNA and protein synthesis, metabolism, cell growth and amino acid transport [174, 175]. Many enzymes are GSH-dependent, including glutathione transferases [176]. GSH is also an essential component of some immune functions such as apoptosis, T-lymphocyte signalling and proliferation, and activation of the nuclear transcription factor NFκB [175, 177-183]. It is these immunological functions of the GSH system that present as somewhat paradoxical: glutathione depletion has a protective effect on various models of apoptotic and necrotic liver injury [180, 184-186]. Glutathione depletion has also been shown to prevent LPS-induced inflammatory lung injury by attenuating neutrophil activation and sequestration [187,

188]. Glutathione depletion has been proposed as a novel anti-inflammatory pharmacotherapy [185, 189]. Dröge *et al* wrote in 1994 that:

“It is clear that GSH is one of the limiting factors that determine the magnitude of immunological functions in vitro and in vivo...we must be prepared to reevaluate one of the central dogmas concerning the role of GSH. GSH was viewed mostly as an important anti-oxidant that protects cells against oxidative stress” [177].

So the findings of Best *et al* [173], where cyanobacterial LPS markedly reduced GSTs in fish embryos after 24 hour exposures, may indicate an LPS-antagonist response, an anti-inflammatory response displaying a different time course to that seen with heterotrophic bacterial LPS, or a consequence of decreased GSH availability, as intracellular GSH efflux increases with the onset of apoptosis [178]. GSTs can be inhibited by GSH conjugates, i.e. their reaction products [190], so this possibility may also need to be considered. In any event, and insofar as innate immune responses in fish embryos can be equated to mammalian cellular activities, these responses are likely to be very complex, with numerous endogenous mediators, feedback loops and time-dependent variation. As an example, the chemoprotectant oltipraz, which is thought to exert anticarcinogenic effects through induction of cytochrome P450 (CYP) enzymes, is now known to transiently (within 24 hours) inhibit some important CYPs and GSTs *in vitro* and *in vivo*. Animals treated for three days showed two-fold-plus increases in the same enzymes [191, 192]. We would be interested to see time-course studies that replicate the work of Best *et al* [173], perhaps continued over several days.

In addition to the studies cited above, nine reports describe the isolation and purification of cyanobacterial LPS for various biomedical, biochemical or structural studies, but no toxicological endpoints were investigated [28, 156, 193-199]. The topic of cyanobacterial LPS was reviewed by Weckesser *et al* [27], and Mayer & Weckesser [200]. These reviews are especially valuable in that they contrast the work done on other photosynthetic prokaryotes, especially the purple non-sulfur bacteria, some of which have been shown to have lipid A structures that are LPS antagonists, as discussed above. No cyanobacterial lipid A structures have been described to date.

In addition to work done on isolated and purified LPS, some reports discuss the activity of cyanobacterial LPS by use of the *Limulus* amoebocyte (LAL) assay. This is a highly sensitive test, though there are trade-offs in terms of specificity, with other bacterial products such as peptidoglycan and glucan capable of registering positive responses [49, 201, 202]. The assay may not always be a reliable predictor of cellular and *in vivo* responses [203]. The study of Rapala *et al* [204] had some significant findings pertaining to the topic of presumed toxicity of cyanobacterial LPS. The authors used the LAL assay to test 26 axenic strains from five cyanobacterial genera; all responses were at least five orders of magnitude lower than reactions to *E. coli* LPS, and several were below the assay's detection limits. This suggests that the lipid A structures of these LPS have some significant and fundamental structural differences to endotoxic lipid A, as the LAL assay does not react to some unusual or modified lipid A structures [87].

***Spirulina platensis*: the importance of exposure route**

S. platensis has a long history of use as a foodstuff, dietary supplement and livestock feed additive, with its probable use dating back to the ninth century in Africa, and the 14th century in Mexico [205]. *Spirulina* is classified taxonomically under the genus *Arthrospira*, order Oscillatoriales; *A. maxima* and *A. fusiformis* are grown commercially in mass culture, but usually designated as “*S. platensis*” [206]. The use of this cyanobacterium was comprehensively reviewed by Ciferri [207], who concluded that extensive nutritional and toxicological testing has shown it to be a safe and valuable protein source. The use of *Spirulina* was briefly reviewed along with that of other edible microalgae by Kay [42], who cited Ciferri [207] in stating that some “negative effects” of *Spirulina* feeding were seen in multigenerational studies and mutagenicity tests. However, this appears to be a misinterpretation on the part of Kay [42], as Ciferri [207] described “negative results” from these studies. The original publications cited by Ciferri [207] were unobtainable. More recent studies seem to support the suggestion that consumption of *Spirulina* is not harmful, and enhances various immune functions [208-212].

A single case report is the exception to the rest of the literature. Iwasa *et al* [213] describe a 52-year-old male taking antihypertensive, hypolipidaemic and hypoglycaemic pharmacotherapy who developed abnormal hepatic enzyme levels two weeks after taking *Spirulina*, presumably on a regular basis. Liver function tests showed a significant deterioration over the following three weeks, after which he was hospitalised. Although a physical examination was unremarkable, a liver biopsy revealed some degenerative changes. Serological studies for a range of viruses were

negative. His medications and *Spirulina* were withdrawn, after which his hepatic function rapidly returned to normal. Hepatotoxicity in this case was attributed to consumption of *Spirulina*, on the basis of temporal relationships between liver function abnormality and recovery with consumption and withdrawal of *Spirulina*, although possible interaction effects with the medications would have been worth considering. This may have been the case with simvastatin, the cholesterol-lowering agent this individual was taking. Simvastatin causes increased proinflammatory cytokine production, and it can potentiate inflammatory responses induced by bacterial products [214]. A brief anecdotal report described two separate occurrences of gastro-intestinal illness in adults following consumption of *Spirulina* pills in Canada in the early 1980s, though there was an indication that one individual's tablets had some bacterial contamination [215].

Recent work has demonstrated that *A. fusiformis* in Kenyan soda lakes is capable of producing the cyanobacterial exotoxins microcystin-YR and anatoxin-a [216, 217]. The implications of this finding are important because cyanobacterial poisoning is implicated in mass mortalities of Lesser Flamingos in the Rift Valley, and *A. fusiformis* is the principal food source for these animals [218, 219]. Common toxigenic cyanobacteria such as *Anabaena* and *Microcystis* are also found in these lakes, and periodically dominate the phytoplankton profile [220], so presumably toxin-producing genes are being transferred between these genera in the field.

The long-standing and widespread consumption of *Arthrospira* spp. illuminates the importance of considering the route of exposure in toxicology studies, and the dangers in this case of presumptive inference of disease from the findings of parenterally

administered LPS. Tornabene *et al* [221] reported a lethal dose of *Spirulina platensis* LPS in the range of 400mg/kg (i.p. mouse), although those findings are not supported by the work of Stewart, where *Spirulina* LPS i.p. injections of 350mg/kg failed to induce either thermoregulatory change or sickness behaviour signs [155]. However, Falconer [222] reported that cell lysates of *Spirulina* were highly toxic to mice when administered by intraperitoneal injection.

Other cyanobacteria are consumed as foods, medicines and dietary supplements. Wild-harvested *Aphanizomenon flos-aquae* was over a decade ago reportedly “consumed by thousands of people without incident” [42], although the lake that produces the commercially available product (Lake Klamath, Oregon) is sometimes subject to contaminating growth of *Microcystis* spp., and some *A. flos-aquae* end-product batches contaminated with microcystins have since been found [223-225]. A Canadian survey analysed for microcystins in cyanobacterial products (*Aphanizomenon*, *Spirulina* and unidentified cyanobacteria) but did not present the results according to the component genera, so it is not clear whether *Spirulina* products (presumably originating from commercial mass cultures) contained microcystins [226]. *Nostoc commune*, a terrestrial species, has a long history of use in China and Scandinavia as food and medicine [227]. The widespread use of these products serves as a reminder that some cyanobacteria, and therefore their LPS, are not harmful by the oral route.

LPS by inhalation

In our opinion, the sole natural exposure route that might explain aquatic cyanobacterial LPS-related illness is via inhalation of aerosolised cells or fragments. Extrapolating from the understanding of Gram-negative bacterial LPS on the respiratory system (as have most if not all of the authors cited in Table 1 for the presumed involvement of cyanobacterial LPS on various disease states), there is a significant and increasing body of literature on the association between endotoxin and pulmonary disease, including asthma, chronic obstructive airway disease and emphysema. Intact bacteria and cell wall fragments are readily aerosolised; bioaerosols of Gram-negative bacteria are widespread contaminants of soils, water and living organisms [228, 229]. Exposure to airborne endotoxin has been associated with a range of occupational respiratory diseases, in industries where high concentrations of organic dusts are liberated, e.g. various agricultural settings, cotton milling, brewing, waste processing [228, 230]. Endotoxin is also found in high concentrations in air pollution and household dust [231]. Endotoxin in some aquatic environments can be aerosolised to disease-related concentrations: Rose *et al* [232] investigated outbreaks of granulomatous pneumonitis affecting lifeguards at an indoor swimming pool, with some affected chronically. Gram-negative bacteria, principally *Pseudomonas* spp, colonised water spray systems in the facility, and increased endotoxin in bio-aerosols was linked to the illnesses.

Michel [230] reviewed experimental inhalation studies of LPS: 4-12 hour periods of dyspnoea, chest tightness, myalgia, shivering, fatigue and malaise with or without fever were reported in a minority of normal subjects. Impaired pulmonary function in the form of bronchoconstriction, changes in non-specific bronchial hyperresponsiveness and reduced alveolar-capillary diffusion were demonstrated.

Asthmatic subjects responded with significant bronchoconstriction lasting five or more hours at doses of 20 µg, whereas normal subjects required doses of 80 µg or more to produce moderate bronchoconstriction [230]. Of interest is the observation that LPS-induced lung changes are associated with neutrophil activation, whereas purified allergen extracts induce bronchial eosinophilia in asthmatic subjects [230, 233]. Normal subjects exhibit a broad range of responses to inhaled LPS: 9% of subjects developed airway obstruction after low-dose inhalation, and 15% showed a negligible airway response to high doses of LPS [231, 234]. Polymorphisms in genes coding for Toll-like receptors, especially Toll-like receptor-4, appear to be important determinants of variability in human responses to inhaled endotoxins. Arbour *et al* [235] showed that a TLR4 sequence mutation is associated with an endotoxin hyporesponsive phenotype in humans.

Schwartz [231] describes asthma as a complex, heterogeneous disease with multiple clinical sub-types, polygenic inheritance and is influenced by many different environmental exposures. Endotoxin is one such exposure, which causes a biologically unique form of asthma [231]. However, exposure to endotoxin early in life may confer beneficial effects: growing up on a farm and exposure to livestock is reportedly associated with a significant reduction in atopy, and there is an inverse correlation between house-dust endotoxin concentration and allergen sensitisation [236-238]. This so-called “hygiene hypothesis” for allergic diseases describes the concept that allergy results from an imbalance in the T-helper cell (Th) subset. According to this theory, exposure to bacterial and viral pathogens in the prenatal and early childhood periods prevents the induction of allergen-associated Th2 cells by establishing a Th1-biased immunity [236, 239]. However, the hygiene hypothesis is

complex and controversial, with contradictory observations and refinements to the theory appearing in the literature. Interested readers are directed to some recent reviews and updates: [239-242]

LPS and allergens initiate inflammatory processes in the airways through different pathways and cytokine cascades: LPS is recognised by innate immune cells, principally alveolar macrophages, which generate pro-inflammatory cytokines such as IL-1, TNF- α and IL-8; the latter cytokine recruits and activates neutrophils. LPS also generates IL-12, which inhibits IgE responses. Allergens generate IL-4, IL-13 and IL-5, the latter cytokine being an activator of eosinophils [239].

In the context of environmental exposures, endotoxins and allergens often occur together; synergistic effects are important considerations in that airway responses to combinations of LPS and allergen are reportedly greater than to either substance alone in atopic asthmatics [239, 243].

The impact of cyanobacteria on respiratory symptoms in atopic individuals is worthy of investigation, and may involve protein allergens and cyanobacterial endotoxin from both toxic and non-toxic blooms. However, the relative burden of cyanobacterial endotoxin to respiratory morbidity will depend on the capacity of the LPS of any given cyanobacterial species to act as an LPS agonist, or as an LPS antagonist, or be biologically inactive; such properties are as yet largely undetermined.

An equally important research effort should be directed towards the capacity of inhaled cyanobacterial exotoxins to generate immunologically non-specific responses

(i.e. in unsensitised individuals) in the bronchial tree. Microcystin-LR appears to be able to efficiently gain access to the circulation by both intranasal and intratracheal routes [244-246], but Gram-negative bacterial endotoxin delivered by inhalation does not cross into the pulmonary vasculature to enter the circulation, and at least one endotoxin-stimulated cytokine – TNF- α – is compartmentalised in the airways [239, 247, 248]. What is open to question is whether the serious cases of pneumonia reported after recreational exposure to cyanobacteria (see Stewart *et al* [249]) may be explained by the induction of an inflammatory response by inhaled cyanobacterial exotoxin, progressing to recruitment and activation of neutrophils and which is confined to the pulmonary alveolar compartment. The possibility is also open as to whether less dramatic reports of respiratory illness may also be explained by a similar, albeit self-limiting process, in healthy, non-atopic individuals. Of course, this speculation does not exclude the likelihood of different, overlapping mechanisms of disease that may explain these phenomena – protein allergens in some cyanobacteria may provoke symptoms in atopic individuals, such symptoms possibly being exacerbated by the presence of cyanobacterial and/or epiphytic bacterial endotoxins.

Cyanobacterial exotoxins may have the capacity to generate respiratory illness in non-atopic individuals, with endotoxins from cyanobacteria or commensal organisms possibly augmenting the symptoms. The potential for cyanobacterial and/or contaminant endotoxin alone to produce symptoms by inhalation exposure remains open, given the observation that LPS can produce measurable airway function changes in animal models and in some healthy individuals [234, 250-252]. Yet it remains unclear whether such experimentally-induced changes in the airway function of healthy volunteers correlate with symptoms of respiratory dysfunction.

Conclusions

Lipid A, the endotoxic moiety of LPS, was in previous decades thought to remain constant across different Gram-negative bacteria [99]. This is now understood to be incorrect; many non-enteric bacteria are seen to vary in their lipid A structures. Because the biological activity of lipid A is determined by its structure, the toxic potential of non-enteric bacteria can vary. Gram-negative organisms occupying different ecological niches will not have the same requirements for growth, and their outer membranes can be expected to vary in order to meet different environmental conditions [31]. Endotoxic potential cannot be assumed to be lacking in the LPS of non-enteric bacteria, however, as seen in the high LPS agonist activity of lipid A from the non-pathogenic purple non-sulfur bacterium *Rubrivivax gelatinosus*, as discussed above. A similar example is given by another group of non-pathogenic bacteria, *Rhizobium* spp, the LPS from some of which are comparable to that of enterobacterial LPS in lethal toxicity and cytokine-inducing activity [253, 254]. Determining the lipid A structures of various nuisance cyanobacteria would be an interesting exercise in itself, but regardless of the findings, proponents of the “cyanobacterial LPS is toxic” cause need to define plausible exposure routes to allow LPS to signal host receptors and initiate a pathogenic cytokine cascade.

From the discussion in this review, we will put the hypothesis that oral consumption of non-toxic cyanobacteria, i.e. absolutely or essentially free of any of the known cyanobacterial exotoxins, will not result in either vomiting or diarrhoea. This

hypothesis would be falsified by experiments that show isolated cyanobacterial LPS or non-toxic crude extracts can cause gastrointestinal signs and/or pathology in a suitable model. Our impression is that reports of G-I symptoms in humans exposed to cyanobacterial products are indications of innate defences being signalled by exotoxins that have breached the intestinal barrier. Once this occurs, and gut permeability is sufficiently disrupted, LPS may well synergise the pathology of cyanotoxins, especially the hepatotoxins. From what little is known to date about the toxic potential of cyanobacterial LPS, i.e. that they are weakly toxic compared to those of the Enterobacteriaceae, gut-derived LPS would seem to be the more likely candidate for augmenting the pathology of cyanotoxins.

In vivo studies of oral exposure to cyanotoxins would be well served by use of a vomiting-capable model, i.e. non-rodent experiments.

There does not appear to be good evidence that cyanobacterial LPS are likely to initiate cutaneous reactions in healthy people exposed in recreational or occupational settings. Cutaneous reactions to cyanobacteria are discussed in detail elsewhere [255-257].

Exposure to bio-aerosols containing cyanobacterial endotoxins may be worthy of investigation, but we are not convinced that cyanobacteria-related acute respiratory illness in non-atopic, non-allergic individuals is not equally or more likely to be explained by inhalation of cyanobacterial exotoxins. If some of the exotoxins turn out to possess ligands that signal innate immune responses (discussed further in [155]), then the large pool of resident alveolar macrophages would be prime candidates for

involvement in respiratory defences. The outbreaks of bath-water fever in Scandinavia and Africa (see accompanying review by Stewart *et al* [249]) were, in our opinion, suspicious of involvement by cyanobacterial exotoxin breakthrough into reticulated supplies. Similar outbreaks in future should be vigorously investigated for cyanotoxins if there is a suggestion of significant cyanobacterial contamination of source water.

In conclusion, LPS of the Enterobacteriaceae are potent immunomodulatory and immunotoxic bacterial products that stimulate a wide variety of responses in mammals, not least of these being a desire to wax lyrical on the topic. Thus:

“Endotoxins possess an intrinsic fascination that is nothing less than fabulous. They seem to have been endowed by Nature with virtues and vices in the exact and glamorous proportions needed to render them irresistible to any investigator who comes to know them” [258].

And:

“The dual role of LPS as effector and target makes it a fascinating molecule which...still hides many miracles. It intrigues at the same time clinical, biological, chemical, and biophysical researchers...” [82].

Facetiousness aside, these workers are pointing out that there is much to learn about the LPS of the most widely studied Gram-negative bacteria, these being the Enterobacteriaceae. The understanding of cyanobacterial LPS is utterly miniscule by

comparison, and we urge caution before continuing to attribute such a disparate range of symptoms in humans to contact with these materials without the required research evidence. Weckesser, Drews and Mayer wrote in 1979 that:

“...the picture obtained with the Enterobacteriaceae cannot be assigned to other Gram-negative bacteria without detailed investigations. Considering the broad spectrum in morphological and physiological diversity of the many taxonomic groups of both photosynthetic bacteria and cyanobacteria, there is a wide open field for studies on the composition of their cell wall.” [27].

Ressom *et al* [259] stated that:

“Given the enormous heterogeneity in LPS from Gram-negative bacteria there is every reason to suspect that the same will apply to cyanobacterial LPS and, due to their taxonomic distance apart, cyanobacterial LPS are likely to be different from those found in Gram-negative bacteria.”

We agree with these statements.

Abbreviations

CYP	cytochrome P450
DNA	deoxyribonucleic acid
G-I	gastrointestinal
GSH	glutathione
GST	glutathione S-transferase

IgE	immunoglobulin E
IL	interleukin
i.p.	intra-peritoneal
LAL assay	<i>Limulus</i> amoebocyte lysate assay
LBP	lipopolysaccharide-binding protein
LD	lethal dose
LPS	lipopolysaccharide/s
SEs	staphylococcal enterotoxins
Th cell	T-helper cell
TLR	Toll-like receptor
TNF- α	tumour necrosis factor-alpha

Competing interests

The authors declare that they have no competing interests.

Author contributions

IS conducted the review; PJS and GRS supervised the work and contributed to redrafting the paper. All authors read and endorsed the final manuscript.

Acknowledgements

This work was supported by grants from the South East Queensland Water Corporation and the Cooperative Research Centre for Water Quality and Treatment.

The National Research Centre for Environmental Toxicology is co-funded by Queensland Health, The University of Queensland, Griffith University and Queensland University of Technology.

References

1. Moe CL: **Waterborne transmission of infectious agents**. In: *Manual of environmental microbiology*. Edited by Hurst CJ, Knudsen GR, McInerney MJ, Stetzenbach LD, Walter MV. Washington, DC: American Society for Microbiology; 1997: 136-152.
2. Sivonen K, Jones G: **Cyanobacterial toxins**. In: *Toxic cyanobacteria in water - a guide to their public health consequences, monitoring and management*. Edited by Chorus I, Bartram J. London: E & FN Spon; 1999: 41-111.
3. Wiegand C, Pflugmacher S: **Ecotoxicological effects of selected cyanobacterial secondary metabolites a short review**. *Toxicol Appl Pharmacol* 2005, **203**(3):201-218.
4. Hitzfeld BC, Hoger SJ, Dietrich DR: **Cyanobacterial toxins: removal during drinking water treatment, and human risk assessment**. *Environ Health Perspect* 2000, **108 Suppl 1**:113-122.
5. Mwaura F, Koyo AO, Zech B: **Cyanobacterial blooms and the presence of cyanotoxins in small high altitude tropical headwater reservoirs in Kenya**. *J Water Health* 2004, **2**(1):49-57.
6. Burch MD: **Cyanobacteria and water quality: new problems and challenges**. In: *Seminar on drinking water quality: Technical and management issues for the 1990s*. Adelaide: Australian Water and Wastewater Association; 1993: 18-24.
7. Carmichael WW, Falconer IR: **Diseases related to freshwater blue-green algal toxins, and control measures**. In: *Algal toxins in seafood and drinking water*. Edited by Falconer IR. London: Academic Press; 1993: 187-209.
8. Codd GA, Edwards C, Beattie KA, Lawton LA, Campbell DL, Bell SG: **Toxins from cyanobacteria (blue-green algae) - The Pringsheim lecture**. In: *Algae, environment and human affairs*. Edited by Wiessner W, Schnepf E, Starr RC. Bristol: Biopress; 1995: 1-17.
9. Bartram J, Carmichael WW, Chorus I, Jones G, Skulberg OM: **Introduction**. In: *Toxic cyanobacteria in water - a guide to their public health consequences, monitoring and management*. Edited by Chorus I, Bartram J. London: E & FN Spon; 1999: 1-14.
10. Codd GA, Bell SG, Kaya K, Ward CJ, Beattie KA, Metcalf JS: **Cyanobacterial toxins, exposure routes and human health**. *Eur J Phycol* 1999, **34**(4):405-415.
11. Kuiper-Goodman T, Falconer I, Fitzgerald J: **Human health aspects**. In: *Toxic cyanobacteria in water - a guide to their public health consequences, monitoring and management*. Edited by Chorus I, Bartram J. London: E & FN Spon; 1999: 113-153.
12. Steffensen D, Burch M, Nicholson B, Drikas M, Baker P: **Management of toxic blue-green algae (cyanobacteria) in Australia**. *Environ Toxicol* 1999, **14**(1):183-195.
13. Codd GA: **Cyanobacterial toxins, the perception of water quality, and the prioritisation of eutrophication control**. *Ecol Eng* 2000, **16**(1):51-60.
14. Carmichael WW: **Assessment of blue-green algal toxins in raw and finished drinking water**. Denver: AWWA Research Foundation and American Water Works Association; 2001.
15. Chorus I, Fastner J: **Recreational exposure to cyanotoxins**. In: *Cyanotoxins - occurrence, causes, consequences*. Edited by Chorus I. Berlin: Springer-Verlag; 2001: 190-199.

16. Carmichael WW: **Freshwater blue-green algae (cyanobacteria) toxins - a review.** In: *The water environment - Algal toxins and health.* Edited by Carmichael WW. New York: Plenum; 1981: 1-13.
17. Codd GA, Poon GK: **Cyanobacterial toxins.** In: *Biochemistry of the algae and cyanobacteria.* Edited by Rogers LJ, Gallon JR. Oxford: Clarendon Press; 1988: 283-296.
18. de Figueiredo DR, Azeiteiro UM, Esteves SM, Gonçalves FJM, Pereira MJ: **Microcystin-producing blooms--a serious global public health issue.** *Ecotoxicol Environ Saf* 2004, **59**(2):151-163.
19. NSW Department of Land and Water Conservation: **What problems are caused by blue-green algae?** 2000.
[<http://www.dlwc.nsw.gov.au/care/water/bga/problems.html>]
20. Shaw G, Garnett C, Moore MR, Florian P: **The predicted impact of climate change on toxic algal (cyanobacterial) blooms and toxin production in Queensland.** *Environ Health* 2001, **1**(4):76-88.
21. Hindman SH, Favero MS, Carson LA, Petersen NJ, Schonberger LB, Solano JT: **Pyrogenic reactions during haemodialysis caused by extramural endotoxin.** *Lancet* 1975, **2**(7938):732-734.
22. Stanier RY, Cohen-Bazire G: **Phototrophic prokaryotes: the cyanobacteria.** *Annu Rev Microbiol* 1977, **31**:225-274.
23. Codd GA: **Blue-green algal toxins: water-borne hazards to health.** In: *Water and public health.* Edited by Golding AMB, Noah N, Stanwell-Smith R. London: Smith-Gordon; 1994: 271-278.
24. Holt JG, Krieg NR, Sneath PHA, Staley JT, Williams ST: **Bergey's manual of determinative bacteriology,** 9th edn. Baltimore: Williams & Wilkins; 1994.
25. Hunter PR: **Waterborne disease. Epidemiology and ecology.** Chichester: John Wiley & Sons; 1997.
26. Duy TN, Lam PKS, Shaw GR, Connell DW: **Toxicology and risk assessment of freshwater cyanobacterial (blue-green algal) toxins in water.** *Rev Environ Contam Toxicol* 2000, **163**:113-185.
27. Weckesser J, Drews G, Mayer H: **Lipopolysaccharides of photosynthetic prokaryotes.** *Annu Rev Microbiol* 1979, **33**:215-239.
28. Weckesser J, Katz A, Drews G, Mayer H, Fromme I: **Lipopolysaccharide containing L-acofriose in the filamentous blue-green alga *Anabaena variabilis*.** *J Bacteriol* 1974, **120**(2):672-678.
29. Drews G: **Fine structure and chemical composition of the cell envelopes.** In: *The biology of blue-green algae.* Edited by Carr NG, Whitton BA. Oxford: Blackwell Scientific; 1973: 99-116.
30. Golecki JR: **Analysis of the structure and development of bacterial membranes (outer, cytoplasmic and intracytoplasmic membranes).** *Methods Microbiol* 1988, **20**:61-77.
31. Lugtenberg B, Van Alphen L: **Molecular architecture and functioning of the outer membrane of *Escherichia coli* and other gram-negative bacteria.** *Biochim Biophys Acta* 1983, **737**(1):51-115.
32. Hobot JA: **Bacterial ultrastructure.** In: *Molecular medical microbiology.* Edited by Sussman M, vol. 1. London: Academic Press; 2002: 7-32.
33. Jürgens UJ, Weckesser J: **The fine structure and chemical composition of the cell wall and sheath layers of cyanobacteria.** *Ann Inst Pasteur Microbiol* 1985, **136A**(1):41-44.

34. Margulis L, Schwartz KV: **Five kingdoms: an illustrated guide to the phyla of life on earth**, 3rd edn. New York: WH Freeman & Co.; 1998.
35. Hughes EO, Gorham PR, Zehnder A: **Toxicity of a unialgal culture of *Microcystis aeruginosa***. *Can J Microbiol* 1958, **4**(3):225-236.
36. Gorham PR: **Toxic waterblooms of blue-green algae**. *Can Vet J* 1960, **1**(6):235-245.
37. McBarron EJ, May V: **Poisoning of sheep in New South Wales by the blue-green alga *Anacystis cyanea* (Kuetz.) Dr. and Dail**. *Aust Vet J* 1966, **42**(12):449-453.
38. Murthy JR, Capindale JB: **A new isolation and structure for the endotoxin from *Microcystis aeruginosa* NRC-1**. *Can J Biochem* 1970, **48**(4):508-510.
39. Heaney SI: **The toxicity of *Microcystis aeruginosa* Kutz from some English reservoirs**. *Water Treat Exam* 1971, **20**(4):235-244.
40. Rabin P, Darbre A: **An improved extraction procedure for the endotoxin from *Microcystis aeruginosa* NRC-1**. *Biochem Soc Trans* 1975, **3**(3):428-430.
41. Elleman TC, Falconer IR, Jackson AR, Runnegar MT: **Isolation, characterization and pathology of the toxin from a *Microcystis aeruginosa* (= *Anacystis cyanea*) bloom**. *Aust J Biol Sci* 1978, **31**(3):209-218.
42. Kay RO: **Microalgae as food and supplement**. *Crit Rev Food Sci Nutr* 1991, **30**(6):555-573.
43. Gentile JH, Maloney TE: **Toxicity and environmental requirements of a strain of *Aphanizomenon flos-aquae* (L.) Ralfs**. *Can J Microbiol* 1969, **15**(2):165-173.
44. Frank AA, Blythe LL, Spencer PS: **Aspects of veterinary neurotoxicology**. In: *Experimental and clinical neurotoxicology*. Edited by Spencer PS, Schaumburg HH. New York: Oxford University Press; 2000: 83-105.
45. Zurawell RW, Chen H, Burke JM, Prepas EE: **Hepatotoxic cyanobacteria: a review of the biological importance of microcystins in freshwater environments**. *J Toxicol Environ Health B Crit Rev* 2005, **8**(1):1-37.
46. Ellis S: **Brevetoxins: chemistry and pharmacology of 'red tide' toxins from *Ptychodiscus brevis* (formerly *Gymnodinium breve*)**. *Toxicon* 1985, **23**(3):469-472.
47. Martich GD, Boujoukos AJ, Suffredini AF: **Response of man to endotoxin**. *Immunobiology* 1993, **187**(3-5):403-416.
48. Schletter J, Heine H, Ulmer AJ, Rietschel ET: **Molecular mechanisms of endotoxin activity**. *Arch Microbiol* 1995, **164**(6):383-389.
49. Henderson B, Poole S, Wilson M: **Bacteria-cytokine interactions in health and disease**. London: Portland Press; 1998.
50. Morrison DC, Raziuddin S: **Lipopolysaccharides and endotoxin**. In: *Immunopharmacology*. Edited by Sirois P, Rola-Pleszczynski M. Amsterdam: Elsevier Biomedical Press; 1982: 169-199.
51. Rietschel ET, Brade H, Holst O, Brade L, Muller-Loennies S, Mamat U, Zahringer U, Beckmann F, Seydel U, Brandenburg K *et al*: **Bacterial endotoxin: Chemical constitution, biological recognition, host response, and immunological detoxification**. *Curr Top Microbiol Immunol* 1996, **216**:39-81.
52. Lynn WA, Golenbock DT: **Lipopolysaccharide antagonists**. *Immunol Today* 1992, **13**(7):271-276.

53. Elsbach P, Weiss J: **The bactericidal/permeability-increasing protein (BPI), a potent element in host-defense against gram-negative bacteria and lipopolysaccharide.** *Immunobiology* 1993, **187**(3-5):417-429.
54. Seydel U, Labischinski H, Kastowsky M, Brandenburg K: **Phase behavior, supramolecular structure, and molecular conformation of lipopolysaccharide.** *Immunobiology* 1993, **187**(3-5):191-211.
55. Olson NC, Hellyer PW, Dodam JR: **Mediators and vascular effects in response to endotoxin.** *Br Vet J* 1995, **151**(5):489-522.
56. Holst O, Ulmer AJ, Brade H, Flad HD, Rietschel ET: **Biochemistry and cell biology of bacterial endotoxins.** *FEMS Immunol Med Microbiol* 1996, **16**(2):83-104.
57. Matsuura M, Kawahara K, Ezaki T, Nakano M: **Biological activities of lipopolysaccharide of Burkholderia (Pseudomonas) pseudomallei.** *FEMS Microbiol Lett* 1996, **137**(1):79-83.
58. Codd GA, Brooks WP, Lawton LA, Beattie KA: **Cyanobacterial toxins in European waters: occurrence, properties, problems and requirements.** In: *Watershed 89 The future for water quality in Europe.* Edited by Wheeler D, Richardson MJ, Bridges J, vol. 2. Oxford: Pergamon Press; 1989: 211-220.
59. Environmental Health Unit - Queensland Health: **Cyanobacteria in recreational and drinking waters.** In: *Environmental health assessment guidelines.* Brisbane: Queensland Government; 2001.
[<http://www.health.qld.gov.au/phs/Documents/ehu/11870.pdf>]
60. Svrcek C, Smith DW: **Cyanobacteria toxins and the current state of knowledge on water treatment options: a review.** *J Environ Eng Sci* 2004, **3**(3):155-185.
61. Burrell R: **Human responses to bacterial endotoxin.** *Circ Shock* 1994, **43**(3):137-153.
62. Hewett JA, Roth RA: **Hepatic and extrahepatic pathobiology of bacterial lipopolysaccharides.** *Pharmacol Rev* 1993, **45**(4):382-411.
63. Heumann D, Glauser MP, Calandra T: **The generation of inflammatory responses.** In: *Molecular medical microbiology.* Edited by Sussman M, vol. 1. London: Academic Press; 2002: 687-727.
64. Hamblin AS: **Regulation of the immune system by pharmacological and biological mediators.** In: *Principles and practice of immunotoxicology.* Edited by Miller K, Turk JL, Nicklin S. Oxford: Blackwell Scientific Publications; 1992: 24-49.
65. Brandtzaeg P: **Significance and pathogenesis of septic shock.** *Curr Top Microbiol Immunol* 1996, **216**:15-37.
66. Wright SD: **Innate recognition of microbial lipids.** In: *Inflammation: Basic principles and clinical correlates.* Edited by Gallin JI, Snyderman R, 3rd edn. Philadelphia: Lippincott Williams & Wilkins; 1999: 525-535.
67. Tobias PS, Tapping RI, Gegner JA: **Endotoxin interactions with lipopolysaccharide-responsive cells.** *Clin Infect Dis* 1999, **28**(3):476-481.
68. Takeda K, Kaisho T, Akira S: **Toll-like receptors.** *Annu Rev Immunol* 2003, **21**:335-376.
69. Janeway CA, Jr., Medzhitov R: **Innate immune recognition.** *Annu Rev Immunol* 2002, **20**:197-216.
70. Schnaitman CA: **The genetics and biosynthesis of lipopolysaccharides.** In: *Molecular medical microbiology.* Edited by Sussman M, vol. 1. London: Academic Press; 2002: 93-136.

71. Morrison DC: **Bacterial endotoxins and pathogenesis.** *Rev Infect Dis* 1983, **5 Suppl 4**:S733-747.
72. Tracey KJ, Beutler B, Lowry SF, Merryweather J, Wolpe S, Milsark IW, Hariri RJ, Fahey TJ, 3rd, Zentella A, Albert JD *et al*: **Shock and tissue injury induced by recombinant human cachectin.** *Science* 1986, **234**(4775):470-474.
73. Galanos C, Freudenberg MA: **Mechanisms of endotoxin shock and endotoxin hypersensitivity.** *Immunobiology* 1993, **187**(3-5):346-356.
74. Müller-Loennies S, Zähringer U, Seydel U, Kusumoto S, Ulmer AJ, Rietschel ET: **What we know and don't know about the chemical and physical structure of lipopolysaccharide in relation to biological activity.** In: *Endotoxin and sepsis Molecular mechanisms of pathogenesis, host resistance, and therapy.* Edited by Levin J, Pollack M, Yokochi T, Nakano M. New York: Wiley-Liss; 1998: 51-72.
75. Qureshi ST, Gros P, Malo D: **The Lps locus: genetic regulation of host responses to bacterial lipopolysaccharide.** *Inflamm Res* 1999, **48**(12):613-620.
76. Sing A, Merlin T, Knopf HP, Nielsen PJ, Loppnow H, Galanos C, Freudenberg MA: **Bacterial induction of beta interferon in mice is a function of the lipopolysaccharide component.** *Infect Immun* 2000, **68**(3):1600-1607.
77. Rietschel ET, Brade L, Lindner B, Zähringer U: **Biochemistry of lipopolysaccharides.** In: *Bacterial endotoxic lipopolysaccharides.* Edited by Morrison DC, Ryan JL, vol. 1. Boca Raton: CRC Press; 1992: 3-41.
78. Ulevitch RJ, Tobias PS: **Recognition of gram-negative bacteria and endotoxin by the innate immune system.** *Curr Opin Immunol* 1999, **11**(1):19-22.
79. Lüderitz O, Galanos C, Lehmann V, Nurminen M, Rietschel ET, Rosenfelder G, Simon M, Westphal O: **Lipid A: Chemical structure and biological activity.** In: *Bacterial lipopolysaccharides The chemistry, biology, and clinical significance of endotoxins.* Edited by Kass EH, Wolff SM. Chicago: University of Chicago Press; 1973: 9-21.
80. Galanos C, Luderitz O, Rietschel ET, Westphal O, Brade H, Brade L, Freudenberg M, Schade U, Imoto M, Yoshimura H *et al*: **Synthetic and natural Escherichia coli free lipid A express identical endotoxic activities.** *Eur J Biochem* 1985, **148**(1):1-5.
81. Erwin AL, Mandrell RE, Munford RS: **Enzymatically deacylated Neisseria lipopolysaccharide (LPS) inhibits murine splenocyte mitogenesis induced by LPS.** *Infect Immun* 1991, **59**(6):1881-1887.
82. Wiese A, Brandenburg K, Ulmer AJ, Seydel U, Müller-Loennies S: **The dual role of lipopolysaccharide as effector and target molecule.** *Biol Chem* 1999, **380**(7-8):767-784.
83. Takayama K, Qureshi N: **Chemical structure of lipid A.** In: *Bacterial endotoxic lipopolysaccharides.* Edited by Morrison DC, Ryan JL, vol. 1. Boca Raton: CRC Press; 1992: 43-65.
84. Jagielo PJ, Quinn TJ, Qureshi N, Schwartz DA: **Grain dust-induced lung inflammation is reduced by Rhodobacter sphaeroides diphosphoryl lipid A.** *Am J Physiol* 1998, **274**(1 Pt 1):L26-31.

85. Masoud H, Lindner B, Weckesser J, Mayer H: **The structure of the lipid A component of *Rhodocyclus gelatinosus* Dr2 lipopolysaccharide.** *System Appl Microbiol* 1990, **13**(3):227-233.
86. Lindberg AA, Weintraub A, Zähringer U, Rietschel ET: **Structure-activity relationships in lipopolysaccharides of *Bacteroides fragilis*.** *Rev Infect Dis* 1990, **12**(Suppl 2):S133-141.
87. Takada H, Kotani S: **Structure-function relationships of lipid A.** In: *Bacterial endotoxic lipopolysaccharides*. Edited by Morrison DC, Ryan JL, vol. 1. Boca Raton: CRC Press; 1992: 107-134.
88. Frieling JTM, Mulder JA, Hendriks T, Curfs JHAJ, van der Linden CJ, Sauerwein RW: **Differential induction of pro- and anti-inflammatory cytokines in whole blood by bacteria: effects of antibiotic treatment.** *Antimicrob Agents Chemother* 1997, **41**(7):1439-1443.
89. Wilson M, Seymour R, Henderson B: **Bacterial perturbation of cytokine networks.** *Infect Immun* 1998, **66**(6):2401-2409.
90. Weintraub A, Zähringer U, Wollenweber HW, Seydel U, Rietschel ET: **Structural characterization of the lipid A component of *Bacteroides fragilis* strain NCTC 9343 lipopolysaccharide.** *Eur J Biochem* 1989, **183**(2):425-431.
91. Griffiss JM, Schneider H, Mandrell RE, Yamasaki R, Jarvis GA, Kim JJ, Gibson BW, Hamadeh R, Apicella MA: **Lipooligosaccharides: the principal glycolipids of the neisserial outer membrane.** *Rev Infect Dis* 1988, **10** Suppl 2:S287-295.
92. Preston A, Mandrell RE, Gibson BW, Apicella MA: **The lipooligosaccharides of pathogenic gram-negative bacteria.** *Crit Rev Microbiol* 1996, **22**(3):139-180.
93. Raetz CRH: **Biosynthesis of lipid A.** In: *Bacterial endotoxic lipopolysaccharides*. Edited by Morrison DC, Ryan JL, vol. 1. Boca Raton: CRC Press; 1992: 67-80.
94. Munford RS, Hall CL: **Detoxification of bacterial lipopolysaccharides (endotoxins) by a human neutrophil enzyme.** *Science* 1986, **234**(4773):203-205.
95. Riedo FX, Munford RS, Campbell WB, Reisch JS, Chien KR, Gerard RD: **Deacylated lipopolysaccharide inhibits plasminogen activator inhibitor-1, prostacyclin, and prostaglandin E2 induction by lipopolysaccharide but not by tumor necrosis factor-alpha.** *J Immunol* 1990, **144**(9):3506-3512.
96. Netea MG, van Deuren M, Kullberg BJ, Cavaillon JM, Van der Meer JW: **Does the shape of lipid A determine the interaction of LPS with Toll-like receptors?** *Trends Immunol* 2002, **23**(3):135-139.
97. Seydel U, Brandenburg K: **Supramolecular structure of lipopolysaccharides and lipid A.** In: *Bacterial endotoxic lipopolysaccharides*. Edited by Morrison DC, Ryan JL, vol. 1. Boca Raton: CRC Press; 1992: 225-250.
98. Schromm AB, Brandenburg K, Loppnow H, Moran AP, Koch MH, Rietschel ET, Seydel U: **Biological activities of lipopolysaccharides are determined by the shape of their lipid A portion.** *Eur J Biochem* 2000, **267**(7):2008-2013.
99. Seydel U, Schromm AB, Blunck R, Brandenburg K: **Chemical structure, molecular conformation, and bioactivity of endotoxins.** *Chem Immunol* 2000, **74**:5-24.

100. Schromm AB, Brandenburg K, Loppnow H, Zahringer U, Rietschel ET, Carroll SF, Koch MH, Kusumoto S, Seydel U: **The charge of endotoxin molecules influences their conformation and IL-6-inducing capacity.** *J Immunol* 1998, **161**(10):5464-5471.
101. Seydel U, Scheel O, Muller M, Brandenburg K, Blunck R: **A K⁺ channel is involved in LPS signaling.** *J Endotoxin Res* 2001, **7**(3):243-247.
102. Brandenburg K, Mayer H, Koch MH, Weckesser J, Rietschel ET, Seydel U: **Influence of the supramolecular structure of free lipid A on its biological activity.** *Eur J Biochem* 1993, **218**(2):555-563.
103. Seydel U, Oikawa M, Fukase K, Kusumoto S, Brandenburg K: **Intrinsic conformation of lipid A is responsible for agonistic and antagonistic activity.** *Eur J Biochem* 2000, **267**(10):3032-3039.
104. Ulmer AJ, Feist W, Heine H, Kirikae T, Kirikae F, Kusumoto S, Kusama T, Brade H, Schade U, Rietschel ET *et al*: **Modulation of endotoxin-induced monokine release in human monocytes by lipid A partial structures that inhibit binding of 125I-lipopolysaccharide.** *Infect Immun* 1992, **60**(12):5145-5152.
105. Moran AP: **Biological and serological characterization of Campylobacter jejuni lipopolysaccharides with deviating core and lipid A structures.** *FEMS Immunol Med Microbiol* 1995, **11**(2):121-130.
106. Rank P: **A possible cause of arteriosclerosis.** *Med Hypotheses* 1985, **17**(2):107-131.
107. Rank P: **Water and arteriosclerosis.** *Med Hypotheses* 1987, **24**(1):87-94.
108. Rank P: **Arteriosclerosis in East Asians.** *Med Hypotheses* 1987, **24**(2):121-129.
109. Ahluwalia KB, Maheshwari N, Deka RC: **Rhinosporidiosis: a study that resolves etiologic controversies.** *Am J Rhinol* 1997, **11**(6):479-483.
110. Ahluwalia KB: **Culture of the organism that causes rhinosporidiosis.** *J Laryngol Otol* 1999, **113**(6):523-528.
111. Ahluwalia KB: **Causative agent of rhinosporidiosis.** *J Clin Microbiol* 2001, **39**(1):413-415.
112. Annadotter H, Cronberg G, Lawton L, Hansson HB, Göthe U, Skulberg O: **An extensive outbreak of gastroenteritis associated with the toxic cyanobacterium *Planktothrix agardhii* (Oscillatoriales, Cyanophyceae) in Scania, south Sweden.** In: *Cyanotoxins - occurrence, causes, consequences.* Edited by Chorus I. Berlin: Springer-Verlag; 2001: 200-208.
113. Giesecke J: **Modern infectious disease epidemiology**, 2nd edn. London: Arnold; 2002.
114. Andrews PL, Hawthorn J: **The neurophysiology of vomiting.** *Baillieres Clin Gastroenterol* 1988, **2**(1):141-168.
115. Grélot L, Miller AD: **Vomiting - its ins and outs.** *News Physiol Sci* 1994, **9**:142-147.
116. Wood JD: **Enteric nervous control of motility in the upper gastrointestinal tract in defensive states.** *Dig Dis Sci* 1999, **44**(8 Suppl):44S-52S.
117. Borison HL: **Area postrema: chemoreceptor circumventricular organ of the medulla oblongata.** *Prog Neurobiol* 1989, **32**(5):351-390.
118. Lang IM: **Noxious stimulation of emesis.** *Dig Dis Sci* 1999, **44**(8 Suppl):58S-63S.
119. Miller AD: **Central mechanisms of vomiting.** *Dig Dis Sci* 1999, **44**(8 Suppl):39S-43S.

120. Barnes JH: **The physiology and pharmacology of emesis.** *Mol Aspects Med* 1984, **7**(5):397-508.
121. Girod V, Bouvier M, Grélot L: **Characterization of lipopolysaccharide-induced emesis in conscious piglets: effects of cervical vagotomy, cyclooxygenase inhibitors and a 5-HT(3) receptor antagonist.** *Neuropharmacology* 2000, **39**(12):2329-2335.
122. Sugiyama H, Hayama T, Yagasaki O: **Emetic action of bacterial endotoxin in the cat.** *Proc Soc Exp Biol Med* 1966, **121**(1):278-281.
123. Sugiyama H, Hayama T: **Abdominal viscera as site of emetic action for staphylococcal enterotoxin in the monkey.** *J Infect Dis* 1965, **115**(4):330-336.
124. Sheth UK, Borison HL: **Central pyrogenic action of *Salmonella typhosa* lipopolysaccharide injected into the lateral cerebral ventricle in cats.** *J Pharmacol Exp Ther* 1960, **130**(4):411-417.
125. Gilbert RP: **Endotoxin shock in the primate.** *Proc Soc Exp Biol Med* 1962, **111**:328-331.
126. Martin WJ, Marcus S: **Relation of pyrogenic and emetic properties of enterobacteriaceal endotoxin and of staphylococcal enterotoxin.** *J Bacteriol* 1964, **87**(5):1019-1026.
127. Sugiyama H, Bergdoll MS, Dack GM: **Early development of a temporary resistance to the emetic action of staphylococcal enterotoxin.** *J Infect Dis* 1962, **111**:233-238.
128. Jett M, Ionin B, Das R, Neill R: **The staphylococcal enterotoxins.** In: *Molecular medical microbiology.* Edited by Sussman M, vol. 2. London: Academic Press; 2002: 1089-1116.
129. Bettelheim KA, Beutin L, Gleier K, Pearce JL, Luke RKJ, Zimmerman S: **Serotypes of *Escherichia coli* isolated from healthy infants in Berlin, Germany and Melbourne, Australia.** *Comp Immunol Microbiol Infect Dis* 2003, **26**(1):55-63.
130. Guarner F, Malagelada JR: **Gut flora in health and disease.** *Lancet* 2003, **361**(9356):512-519.
131. Nanthakumar NN, Fusunyan RD, Sanderson I, Walker WA: **Inflammation in the developing human intestine: A possible pathophysiologic contribution to necrotizing enterocolitis.** *Proc Natl Acad Sci U S A* 2000, **97**(11):6043-6048.
132. Turner AK, Terry TD, Sack DA, Londono-Arcila P, Darsley MJ: **Construction and characterization of genetically defined aro omp mutants of enterotoxigenic *Escherichia coli* and preliminary studies of safety and immunogenicity in humans.** *Infect Immun* 2001, **69**(8):4969-4979.
133. Nataro JP: **Diarrhoeagenic *Escherichia coli*.** In: *Molecular medical microbiology.* Edited by Sussman M, vol. 2. London: Academic Press; 2002: 1463-1504.
134. Farthing MJ: **Novel targets for the pharmacotherapy of diarrhoea: a view for the millennium.** *J Gastroenterol Hepatol* 2000, **15** Suppl:G38-45.
135. Ahmed ZU, Sarker MR, Sack DA: **Protection of adult rabbits and monkeys from lethal shigellosis by oral immunization with a thymine-requiring and temperature-sensitive mutant of *Shigella flexneri* Y.** *Vaccine* 1990, **8**(2):153-158.
136. Kollaritsch H, Cryz SJ, Jr., Lang AB, Herzog C, Que JU, Wiedermann G: **Local and systemic immune responses to combined vibrio cholerae**

- CVD103-HgR and salmonella typhi ty21a live oral vaccines after primary immunization and reimmunization.** *Vaccine* 2000, **18**(26):3031-3039.
137. Salerno-Goncalves R, Wyant TL, Pasetti MF, Fernandez-Vina M, Tacket CO, Levine MM, Sztein MB: **Concomitant induction of CD4+ and CD8+ T cell responses in volunteers immunized with Salmonella enterica serovar typhi strain CVD 908-htrA.** *J Immunol* 2003, **170**(5):2734-2741.
 138. Altenhoefer A, Oswald S, Sonnenborn U, Enders C, Schulze J, Hacker J, Oelschlaeger TA: **The probiotic Escherichia coli strain Nissle 1917 interferes with invasion of human intestinal epithelial cells by different enteroinvasive bacterial pathogens.** *FEMS Immunol Med Microbiol* 2004, **40**(3):223-229.
 139. Stewart I, Webb PM, Schluter PJ, Fleming LE, Burns JW, Jr., Gantar M, Backer LC, Shaw GR: **Epidemiology of recreational exposure to freshwater cyanobacteria - an international prospective cohort study.** *Submitted for publication* 2005.
 140. Oketani K, Inoue T, Murakami M: **Effect of E3040, an inhibitor of 5-lipoxygenase and thromboxane synthase, on rat bowel damage induced by lipopolysaccharide.** *Eur J Pharmacol* 2001, **427**(2):159-166.
 141. Yang JM, Han DW, Xie CM, Liang QC, Zhao YC, Ma XH: **Endotoxins enhance hepatocarcinogenesis induced by oral intake of thioacetamide in rats.** *World J Gastroenterol* 1998, **4**(2):128-132.
 142. Yoshino S, Sasatomi E, Mori Y, Sagai M: **Oral administration of lipopolysaccharide exacerbates collagen-induced arthritis in mice.** *J Immunol* 1999, **163**(6):3417-3422.
 143. Roth RA, Harkema JR, Pestka JP, Ganey PE: **Is exposure to bacterial endotoxin a determinant of susceptibility to intoxication from xenobiotic agents?** *Toxicol Appl Pharmacol* 1997, **147**(2):300-311.
 144. Yee SB, Kinser S, Hill DA, Barton CC, Hotchkiss JA, Harkema JR, Ganey PE, Roth RA: **Synergistic hepatotoxicity from coexposure to bacterial endotoxin and the pyrrolizidine alkaloid monocrotaline.** *Toxicol Appl Pharmacol* 2000, **166**(3):173-185.
 145. Ganey PE, Roth RA: **Concurrent inflammation as a determinant of susceptibility to toxicity from xenobiotic agents.** *Toxicology* 2001, **169**(3):195-208.
 146. Jackson AR, McInnes A, Falconer IR, Runnegar MT: **Clinical and pathological changes in sheep experimentally poisoned by the blue-green alga *Microcystis aeruginosa*.** *Vet Pathol* 1984, **21**(1):102-113.
 147. Hawkins PR, Runnegar MT, Jackson AR, Falconer IR: **Severe hepatotoxicity caused by the tropical cyanobacterium (blue-green alga) *Cylindrospermopsis raciborskii* (Woloszynska) Seenaya and Subba Raju isolated from a domestic water supply reservoir.** *Appl Environ Microbiol* 1985, **50**(5):1292-1295.
 148. Falconer IR, Dornbusch M, Moran G, Yeung SK: **Effect of the cyanobacterial (blue-green algal) toxins from *Microcystis aeruginosa* on isolated enterocytes from the chicken small intestine.** *Toxicon* 1992, **30**(7):790-793.
 149. Falconer IR: **Health problems from exposure to cyanobacteria and proposed safety guidelines for drinking and recreational water.** In: *Detection methods for cyanobacterial toxins.* Edited by Codd GA, Jefferies

- TM, Keevil CW, Potter E. Cambridge: The Royal Society of Chemistry; 1994: 3-10.
150. Saker ML, Thomas AD, Norton JH: **Cattle mortality attributed to the toxic cyanobacterium *Cylindrospermopsis raciborskii* in an outback region of north Queensland.** *Environ Toxicol* 1999, **14**(1):179-182.
 151. Seawright AA, Nolan CC, Shaw GR, Chiswell RK, Norris RL, Moore MR, Smith MJ: **The oral toxicity for mice of the tropical cyanobacterium *Cylindrospermopsis raciborskii* (Woloszynska).** *Environ Toxicol* 1999, **14**(1):135-142.
 152. Fastner J, Heinze R, Humpage AR, Mischke U, Eaglesham GK, Chorus I: ***Cylindrospermopsis* occurrence in two German lakes and preliminary assessment of toxicity and toxin production of *Cylindrospermopsis raciborskii* (cyanobacteria) isolates.** *Toxicon* 2003, **42**(3):313-321.
 153. Rietschel RL, Fowler JF, Jr.: **Fisher's Contact Dermatitis**, 5th edn. Philadelphia: Lippincott Williams & Wilkins; 2001.
 154. Arnold HL, Jr., Odom RB, James WD: **Andrews' diseases of the skin. Clinical dermatology**, 8th edn. Philadelphia: W.B. Saunders; 1990.
 155. Stewart I: **Recreational exposure to freshwater cyanobacteria: epidemiology, dermal toxicity and biological activity of cyanobacterial lipopolysaccharides.** *PhD thesis*. Brisbane: University of Queensland; 2004. [<http://eprint.uq.edu.au/archive/00001883/>]
 156. Jürgens UJ, Martin C, Weckesser J: **Cell wall constituents of *Microcystis* sp. PCC 7806.** *FEMS Microbiol Lett* 1989, **53**(1-2):47-51.
 157. Papageorgiou J, Linke TA, Kapralos C, Nicholson BC, Steffensen DA: **Extraction of cyanobacterial endotoxin.** *Environ Toxicol* 2004, **19**(1):82-87.
 158. Raziuddin S, Siegelman HW, Tornabene TG: **Lipopolysaccharides of the cyanobacterium *Microcystis aeruginosa*.** *Eur J Biochem* 1983, **137**(1-2):333-336.
 159. Scholtissek B, Jürgens UJ, Weckesser J: **Purification and electrophoretic pattern of the lipopolysaccharide of *Microcystis* sp. PCC 7806.** *Arch Hydrobiol Suppl Algal Stud* 1991, **64**:361-368.
 160. Katz A, Weckesser J, Drews G, Mayer H: **Chemical and biological studies on the lipopolysaccharide (O-antigen) of *Anacystis nidulans*.** *Arch Microbiol* 1977, **113**(3):247-256.
 161. Utili R, Abernathy CO, Zimmerman HJ: **Endotoxin effects on the liver.** *Life Sci* 1977, **20**(4):553-568.
 162. Musson RA, Morrison DC, Ulevitch RJ: **Distribution of endotoxin (lipopolysaccharide) in the tissues of lipopolysaccharide-responsive and -unresponsive mice.** *Infect Immun* 1978, **21**(2):448-457.
 163. Galanos C, Freudenberg MA, Katschinski T, Salomao R, Mossmann H, Kumazawa Y: **Tumor necrosis factor and host response to endotoxin.** In: *Bacterial endotoxic lipopolysaccharides*. Edited by Ryan JL, Morrison DC, vol. 2. Boca Raton: CRC Press; 1992: 75-104.
 164. Kirkland TN, Ziegler EJ: **An immunoprotective monoclonal antibody to lipopolysaccharide.** *J Immunol* 1984, **132**(5):2590-2592.
 165. Ruggiero V, Piovesan P, Fabrizi C, Lauro GM, Campo S, Albertoni C, Nucera E, Carminati P, Ghirardi O: ***In vivo* and *In vitro* cytokine modulatory activity of newly synthesised 2-aminotetraline derivatives.** *Shock* 2004, **21**(1):77-85.

166. Buttke TM, Ingram LO: **Comparison of lipopolysaccharides from *Agmenellum quadruplicatum* to *Escherichia coli* and *Salmonella typhimurium* by using thin-layer chromatography.** *J Bacteriol* 1975, **124**(3):1566-1573.
167. Keleti G, Sykora JL, Lippy EC, Shapiro MA: **Composition and biological properties of lipopolysaccharides isolated from *Schizothrix calcicola* (Ag.) Gomont (cyanobacteria).** *Appl Environ Microbiol* 1979, **38**(3):471-477.
168. Keleti G, Sykora JL: **Production and properties of cyanobacterial endotoxins.** *Appl Environ Microbiol* 1982, **43**(1):104-109.
169. Movat HZ, Burrowes CE: **The local Shwartzman reaction: endotoxin-mediated inflammatory and thrombo-hemorrhagic lesions.** In: *Handbook of endotoxin Vol 3: Cellular biology of endotoxin.* Edited by Berry LJ. Amsterdam: Elsevier Science Publishers; 1985: 260-302.
170. Galdiero F, Sommese L, Scarfogliero P, Galdiero M: **Biological activities-- lethality, Shwartzman reaction and pyrogenicity--of *Salmonella typhimurium* porins.** *Microb Pathog* 1994, **16**(2):111-119.
171. Weise G, Drews G, Jann B, Jann K: **Identification and analysis of a lipopolysaccharide in cell walls of the blue-green alga *Anacystis nidulans*.** *Arch Mikrobiol* 1970, **71**(1):89-98.
172. Schmidt W, Drews G, Weckesser J, Fromme I, Borowiak D: **Characterization of the lipopolysaccharides from eight strains of the cyanobacterium *Synechococcus*.** *Arch Microbiol* 1980, **127**(3):209-215.
173. Best JH, Pflugmacher S, Wiegand C, Eddy FB, Metcalf JS, Codd GA: **Effects of enteric bacterial and cyanobacterial lipopolysaccharides, and of microcystin-LR, on glutathione S-transferase activities in zebra fish (*Danio rerio*).** *Aquat Toxicol* 2002, **60**(3-4):223-231.
174. Kretzschmar M, Klinger W: **The hepatic glutathione system--influences of xenobiotics.** *Exp Pathol* 1990, **38**(3):145-164.
175. Hentze H, Latta M, Künstle G, Lucas R, Wendel A: **Redox control of hepatic cell death.** *Toxicol Lett* 2003, **139**(2-3):111-118.
176. Uhlig S, Wendel A: **The physiological consequences of glutathione variations.** *Life Sci* 1992, **51**(14):1083-1094.
177. Dröge W, Schulze-Osthoff K, Mihm S, Galter D, Schenk H, Eck HP, Roth S, Gmünder H: **Functions of glutathione and glutathione disulfide in immunology and immunopathology.** *FASEB J* 1994, **8**(14):1131-1138.
178. van den Dobbelen DJ, Nobel CSI, Schlegel J, Cotgreave IA, Orrenius S, Slater AFG: **Rapid and specific efflux of reduced glutathione during apoptosis induced by anti-Fas/APO-1 antibody.** *J Biol Chem* 1996, **271**(26):15420-15427.
179. Hall AG: **The role of glutathione in the regulation of apoptosis.** *Eur J Clin Invest* 1999, **29**(3):238-245.
180. Hentze H, Künstle G, Volbracht C, Ertel W, Wendel A: **CD95-mediated murine hepatic apoptosis requires an intact glutathione status.** *Hepatology* 1999, **30**(1):177-185.
181. Hehner SP, Breitkreutz R, Shubinsky G, Unsoeld H, Schulze-Osthoff K, Schmitz ML, Dröge W: **Enhancement of T cell receptor signaling by a mild oxidative shift in the intracellular thiol pool.** *J Immunol* 2000, **165**(8):4319-4328.

182. Hentze H, Schmitz I, Latta M, Krueger A, Krammer PH, Wendel A: **Glutathione dependence of caspase-8 activation at the death-inducing signaling complex.** *J Biol Chem* 2002, **277**(7):5588-5595.
183. Musallam L, Éthier C, Haddad PS, Denizeau F, Bilodeau M: **Resistance to Fas-induced apoptosis in hepatocytes: role of GSH depletion by cell isolation and culture.** *Am J Physiol Gastrointest Liver Physiol* 2002, **283**(3):G709-718.
184. Tiegs G, Wendel A: **Leukotriene-mediated liver injury.** *Biochem Pharmacol* 1988, **37**(13):2569-2573.
185. Jones JJ, Fan J, Nathens AB, Kapus A, Shekhman M, Marshall JC, Parodo J, Rotstein OD: **Redox manipulation using the thiol-oxidizing agent diethyl maleate prevents hepatocellular necrosis and apoptosis in a rodent endotoxemia model.** *Hepatology* 1999, **30**(3):714-724.
186. Hentze H, Gantner F, Kolb SA, Wendel A: **Depletion of hepatic glutathione prevents death receptor-dependent apoptotic and necrotic liver injury in mice.** *Am J Pathol* 2000, **156**(6):2045-2056.
187. Nathens AB, Marshall JC, Watson RWG, Dackiw APB, Rotstein OD: **Diethylmaleate attenuates endotoxin-induced lung injury.** *Surgery* 1996, **120**(2):360-366.
188. Nathens AB, Bitar R, Watson RWG, Issekutz TB, Marshall JC, Dackiw APB, Rotstein OD: **Thiol-mediated regulation of ICAM-1 expression in endotoxin-induced acute lung injury.** *J Immunol* 1998, **160**(6):2959-2966.
189. Szászi K, Jones JJ, Nathens AB, Lo AY, Marsden PA, Kapus A, Rotstein OD: **Glutathione depletion inhibits lipopolysaccharide-induced intercellular adhesion molecule 1 synthesis.** *Free Radic Biol Med* 2005, **38**(10):1333-1343.
190. Chasseaud LF: **The role of glutathione and glutathione S-transferases in the metabolism of chemical carcinogens and other electrophilic agents.** *Adv Cancer Res* 1979, **29**:175-274.
191. Langouët S, Mahéo K, Berthou F, Morel F, Lagadic-Gossman D, Glaise D, Coles B, Ketterer B, Guillouzo A: **Effects of administration of the chemoprotective agent oltipraz on CYP1A and CYP2B in rat liver and rat hepatocytes in culture.** *Carcinogenesis* 1997, **18**(7):1343-1349.
192. Mahéo K, Morel F, Antras-Ferry J, Langouët S, Desmots F, Corcos L, Guillouzo A: **Endotoxin suppresses the oltipraz-mediated induction of major hepatic glutathione transferases and cytochromes P450 in the rat.** *Hepatology* 1998, **28**(6):1655-1662.
193. Schnayer N, Jenifer FG: **Inactivation of blue-green alga virus, AS-1, by isolated host lipopolysaccharide.** *Proc Am Phytopathol Soc* 1974, **1**:144.
194. Samimi B, Drews G: **Adsorption of cyanophage AS-1 to unicellular cyanobacteria and isolation of receptor material from Anacystis nidulans.** *J Virol* 1978, **25**(1):164-174.
195. Jones JH, Yopp JH: **Cell wall constituents of *Aphanothece halophytica* (cyanophyta).** *J Phycol* 1979, **15**(1):62-66.
196. Schmidt W, Drews G, Weckesser J, Mayer H: **Lipopolysaccharides in four strains of the unicellular cyanobacterium *Synechocystis*.** *Arch Microbiol* 1980, **127**(3):217-222.
197. Martin C, Codd GA, Siegelman HW, Weckesser J: **Lipopolysaccharides and polysaccharides of the cell envelope of toxic *Microcystis aeruginosa* strains.** *Arch Microbiol* 1989, **152**(1):90-94.

198. Schneider S, Jürgens UJ: **Cell wall and sheath constituents of the cyanobacterium *Gloeobacter violaceus***. *Arch Microbiol* 1991, **156**(4):312-318.
199. Xu X, Khudyakov I, Wolk CP: **Lipopolysaccharide dependence of cyanophage sensitivity and aerobic nitrogen fixation in *Anabaena* sp. strain PCC 7120**. *J Bacteriol* 1997, **179**(9):2884-2891.
200. Mayer H, Weckesser J: **'Unusual' lipid A's: structures, taxonomical relevance and potential value for endotoxin research**. In: *Handbook of endotoxin - Volume 1: Chemistry of endotoxin*. Edited by Rietschel ET. Amsterdam: Elsevier; 1984: 221-247.
201. Mikami T, Nagase T, Matsumoto T, Suzuki S, Suzuki M: **Gelation of *Limulus* amoebocyte lysate by simple polysaccharides**. *Microbiol Immunol* 1982, **26**(5):403-409.
202. Roslansky PF, Novitsky TJ: **Sensitivity of *Limulus* amoebocyte lysate (LAL) to LAL-reactive glucans**. *J Clin Microbiol* 1991, **29**(11):2477-2483.
203. Tanamoto K: **Dissociation of endotoxic activities in a chemically synthesized lipid A precursor after acetylation**. *Infect Immun* 1995, **63**(2):690-692.
204. Rapala J, Lahti K, Rasanen LA, Esala AL, Niemela SI, Sivonen K: **Endotoxins associated with cyanobacteria and their removal during drinking water treatment**. *Water Res* 2002, **36**(10):2627-2635.
205. Abdulqader G, Barsanti L, Tredici MR: **Harvest of *Arthrospira platensis* from Lake Kossorom (Chad) and its household use among the Kanembu**. *J Appl Phycol* 2000, **12**(3-5):493-498.
206. Komárek J, Komárková J, Kling H: **Filamentous cyanobacteria**. In: *Freshwater algae of North America: ecology and classification*. Edited by Wehr JD, Sheath RG. Massachusetts: Academic Press; 2003: 117-196.
207. Ciferri O: **Spirulina, the edible microorganism**. *Microbiol Rev* 1983, **47**(4):551-578.
208. Belay A, Ota Y, Miyakawa K, Shimamatsu H: **Current knowledge on potential health benefits of *Spirulina***. *J Appl Phycol* 1993, **5**:235-241.
209. Hayashi O, Katoh T, Okuwaki Y: **Enhancement of antibody production in mice by dietary *Spirulina platensis***. *J Nutr Sci Vitaminol (Tokyo)* 1994, **40**(5):431-441.
210. Qureshi MA, Garlich JD, Kidd MT: **Dietary *Spirulina platensis* enhances humoral and cell-mediated immune functions in chickens**. *Immunopharmacol Immunotoxicol* 1996, **18**(3):465-476.
211. Salazar M, Martínez E, Madrigal E, Ruiz LE, Chamorro GA: **Subchronic toxicity study in mice fed *Spirulina maxima***. *J Ethnopharmacol* 1998, **62**(3):235-241.
212. Al-Batshan HA, Al-Mufarrej SI, Al-Homaidan AA, Qureshi MA: **Enhancement of chicken macrophage phagocytic function and nitrite production by dietary *Spirulina platensis***. *Immunopharmacol Immunotoxicol* 2001, **23**(2):281-289.
213. Iwasa M, Yamamoto M, Tanaka Y, Kaito M, Adachi Y: ***Spirulina*-associated hepatotoxicity**. *Am J Gastroenterol* 2002, **97**(12):3212-3213.
214. Matsumoto M, Einhaus D, Gold ES, Aderem A: **Simvastatin Augments Lipopolysaccharide-Induced Proinflammatory Responses in Macrophages by Differential Regulation of the c-Fos and c-Jun Transcription Factors**. *J Immunol* 2004, **172**(12):7377-7384.

215. Gorham PR, Carmichael WW: **Hazards of freshwater blue-green algae (cyanobacteria)**. In: *Algae and human affairs*. Edited by Lembi CA, Waaland JR. Cambridge: Cambridge University Press; 1988: 403-431.
216. Ballot A, Krienitz L, Kotut K, Wiegand C, Metcalf JS, Codd GA, Pflugmacher S: **Cyanobacteria and cyanobacterial toxins in three alkaline Rift Valley lakes of Kenya--Lakes Bogoria, Nakuru and Elmenteita**. *J Plankton Res* 2004, **26**(8):925-935.
217. Ballot A, Krienitz L, Kotut K, Wiegand C, Pflugmacher S: **Cyanobacteria and cyanobacterial toxins in the alkaline crater lakes Sonachi and Simbi, Kenya**. *Harmful Algae* 2005, **4**(1):139-150.
218. Codd GA, Metcalf JS, Morrison LF, Krienitz L, Ballot A, Pflugmacher S, Wiegand C, Kotut K: **Susceptibility of flamingos to cyanobacterial toxins via feeding**. *Vet Rec* 2003, **152**(23):722-723.
219. Krienitz L, Ballot A, Kotut K, Wiegand C, Pütz S, Metcalf JS, Codd GA, Pflugmacher S: **Contribution of hot spring cyanobacteria to the mysterious deaths of Lesser Flamingos at Lake Bogoria, Kenya**. *FEMS Microbiol Ecol* 2003, **43**(2):141-148.
220. Ndeti R, Muhandiki VS: **Mortalities of lesser flamingos in Kenyan Rift Valley saline lakes and the implications for sustainable management of the lakes**. *Lakes Reserv Res Manage* 2005, **10**(1):51-58.
221. Tornabene TG, Bourne TF, Raziuddin S, Ben-Amotz A: **Lipid and lipopolysaccharide constituents of cyanobacterium *Spirulina platensis* (Cyanophyceae, Nostocales)**. *Mar Ecol Prog Ser* 1985, **22**(2):121-125.
222. Falconer IR: **An overview of problems caused by toxic blue-green algae (cyanobacteria) in drinking and recreational water**. *Environ Toxicol* 1999, **14**(1):5-12.
223. Schaeffer DJ, Malpas PB, Barton LL: **Risk assessment of microcystin in dietary *Aphanizomenon flos-aquae***. *Ecotoxicol Environ Saf* 1999, **44**(1):73-80.
224. Gilroy DJ, Kauffman KW, Hall RA, Huang X, Chu FS: **Assessing potential health risks from microcystin toxins in blue-green algae dietary supplements**. *Environ Health Perspect* 2000, **108**(5):435-439.
225. Saker ML, Jungblut AD, Neilan BA, Rawn DFK, Vasconcelos VM: **Detection of microcystin synthetase genes in health food supplements containing the freshwater cyanobacterium *Aphanizomenon flos-aquae***. *Toxicon* 2005, **46**(5):555-562.
226. Lawrence JF, Niedzwiadek B, Menard C, Lau BPY, Lewis D, Kuper-Goodman T, Carbone S, Holmes C: **Comparison of liquid chromatography/mass spectrometry, ELISA, and phosphatase assay for the determination of microcystins in blue-green algae products**. *JAOAC Int* 2001, **84**(4):1035-1044.
227. Brüll LP, Huang Z, Thomas-Oates JE, Paulsen BS, Cohen EH, Michaelsen TE: **Studies of polysaccharides from three edible species of *Nostoc* (cyanobacteria) with different colony morphologies: Structural characterization and effect on the complement system of polysaccharides from *Nostoc commune***. *J Phycol* 2000, **36**(5):871-881.
228. Olenchock SA: **Airborne endotoxin**. In: *Manual of environmental microbiology*. Edited by Hurst CJ, Knudsen GR, McInerney MJ, Stetzenbach LD, Walter MV. Washington: ASM Press; 1997: 661-665.

229. Stetzenbach LD: **Introduction to aerobiology**. In: *Manual of environmental microbiology*. Edited by Hurst CJ, Knudsen GR, McInerney MJ, Stetzenbach LD, Walter MV. Washington: ASM Press; 1997: 619-628.
230. Michel O: **Systemic and local airways inflammatory response to endotoxin**. *Toxicology* 2000, **152**(1-3):25-30.
231. Schwartz DA: **Does inhalation of endotoxin cause asthma?** *Am J Respir Crit Care Med* 2001, **163**(2):305-306.
232. Rose CS, Martyny JW, Newman LS, Milton DK, King TE, Jr., Beebe JL, McCammon JB, Hoffman RE, Kreiss K: **"Lifeguard lung": endemic granulomatous pneumonitis in an indoor swimming pool**. *Am J Public Health* 1998, **88**(12):1795-1800.
233. Hunt LW, Gleich GJ, Ohnishi T, Weiler DA, Mansfield ES, Kita H, Sur S: **Endotoxin contamination causes neutrophilia following pulmonary allergen challenge**. *Am J Respir Crit Care Med* 1994, **149**(6):1471-1475.
234. Kline JN, Cowden JD, Hunninghake GW, Schutte BC, Watt JL, Wohlford-Lenane CL, Powers LS, Jones MP, Schwartz DA: **Variable airway responsiveness to inhaled lipopolysaccharide**. *Am J Respir Crit Care Med* 1999, **160**(1):297-303.
235. Arbour NC, Lorenz E, Schutte BC, Zabner J, Kline JN, Jones M, Frees K, Watt JL, Schwartz DA: **TLR4 mutations are associated with endotoxin hyporesponsiveness in humans**. *Nat Genet* 2000, **25**(2):187-191.
236. Herz U, Lacy P, Renz H, Erb K: **The influence of infections on the development and severity of allergic disorders**. *Curr Opin Immunol* 2000, **12**(6):632-640.
237. Riedler J, Eder W, Oberfeld G, Schreuer M: **Austrian children living on a farm have less hay fever, asthma and allergic sensitization**. *Clin Exp Allergy* 2000, **30**(2):194-200.
238. Riedler J, Braun-Fahrlander C, Eder W, Schreuer M, Waser M, Maisch S, Carr D, Schierl R, Nowak D, von Mutius E: **Exposure to farming in early life and development of asthma and allergy: a cross-sectional survey**. *Lancet* 2001, **358**(9288):1129-1133.
239. Reed CE, Milton DK: **Endotoxin-stimulated innate immunity: A contributing factor for asthma**. *J Allergy Clin Immunol* 2001, **108**(2):157-166.
240. Douwes J, Pearce N, Heederik D: **Does environmental endotoxin exposure prevent asthma?** *Thorax* 2002, **57**(1):86-90.
241. Yazdanbakhsh M, Kremsner PG, van Ree R: **Allergy, parasites, and the hygiene hypothesis**. *Science* 2002, **296**(5567):490-494.
242. Douwes J, Le Gros G, Gibson P, Pearce N: **Can bacterial endotoxin exposure reverse atopy and atopic disease?** *J Allergy Clin Immunol* 2004, **114**(5):1051-1054.
243. Eldridge MW, Peden DB: **Airway response to concomitant exposure with endotoxin and allergen in atopic asthmatics**. *J Toxicol Environ Health A* 2000, **61**(1):27-37.
244. Creasia DA: **Acute inhalation toxicity of microcystin-LR with mice**. *Toxicon* 1990, **28**(6):605.
245. Fitzgeorge RB, Clark SA, Keevil CW: **Routes of intoxication**. In: *Detection methods for cyanobacterial toxins*. Edited by Codd GA, Jefferies TM, Keevil CW, Potter E. Cambridge: The Royal Society of Chemistry; 1994: 69-74.

246. Ito E, Kondo F, Harada K: **Intratracheal administration of microcystin-LR, and its distribution.** *Toxicon* 2001, **39**(2-3):265-271.
247. Nelson S, Bagby GJ, Bainton BG, Wilson LA, Thompson JJ, Summer WR: **Compartmentalization of intraalveolar and systemic lipopolysaccharide-induced tumor necrosis factor and the pulmonary inflammatory response.** *J Infect Dis* 1989, **159**(2):189-194.
248. Ghofrani HA, Rosseau S, Walmrath D, Kaddus W, Kramer A, Grimminger F, Lohmeyer J, Seeger W: **Compartmentalized lung cytokine release in response to intravascular and alveolar endotoxin challenge.** *Am J Physiol* 1996, **270**(1 Pt 1):L62-68.
249. Stewart I, Webb PM, Schluter PJ, Shaw GR: **Recreational and occupational field exposure to freshwater cyanobacteria - a review of anecdotal and case reports, epidemiological studies and the challenges for epidemiologic assessment.** *Submitted for publication* 2005.
250. Poynter ME, Irvin CG, Janssen-Heininger YM: **A prominent role for airway epithelial NF-kappa B activation in lipopolysaccharide-induced airway inflammation.** *J Immunol* 2003, **170**(12):6257-6265.
251. Okamoto T, Gohil K, Finkelstein EI, Bove P, Akaike T, van der Vliet A: **Multiple contributing roles for NOS2 in LPS-induced acute airway inflammation in mice.** *Am J Physiol Lung Cell Mol Physiol* 2004, **286**(1):L198-209.
252. Spond J, Billah MM, Chapman RW, Egan RW, Hey JA, House A, Kreutner W, Minnicozzi M: **The role of neutrophils in LPS-induced changes in pulmonary function in conscious rats.** *Pulm Pharmacol Ther* 2004, **17**(3):133-140.
253. Urbanik-Sypniewska T, Seydel U, Greck M, Weckesser J, Mayer H: **Chemical studies on the lipopolysaccharide of *Rhizobium meliloti* 10406 and its lipid A region.** *Arch Microbiol* 1989, **152**(6):527-532.
254. Urbanik-Sypniewska T, Choma A, Kutkowska J, Kaminska T, Kandeferszyszen M, Russa R, Dolecka J: **Cytokine inducing activities of rhizobial and mesorhizobial lipopolysaccharides of different lethal toxicity.** *Immunobiology* 2000, **202**(4):408-420.
255. Pilotto L, Hobson P, Burch MD, Ranmuthugala G, Attewell R, Weightman W: **Acute skin irritant effects of cyanobacteria (blue-green algae) in healthy volunteers.** *Aust N Z J Public Health* 2004, **28**(3):220-224.
256. Stewart I, Robertson IM, Webb PM, Schluter PJ, Shaw GR: **Cutaneous hypersensitivity reactions to freshwater cyanobacteria - human volunteer studies.** *Submitted for publication* 2005.
257. Stewart I, Seawright AA, Schluter PJ, Shaw GR: **Primary irritant and delayed-contact hypersensitivity reactions to the freshwater cyanobacterium *Cylindrospermopsis raciborskii* and its associated toxin cylindrospermopsin.** *Submitted for publication* 2005.
258. Bennett IL, Jr.: **Approaches to the mechanisms of endotoxin action.** In: *Bacterial endotoxins.* Edited by Landy M, Braun W. New Brunswick: Institute of Microbiology, Rutgers, The State University of New Jersey; 1964: xiii-xvi.
259. Resson R, Soong FS, Fitzgerald J, Turczynowicz L, El Saadi O, Roder D, Maynard T, Falconer I: **Health effects of toxic cyanobacteria (blue-green algae).** Canberra: National Health and Medical Research Council & Australian Government Publishing Service; 1994.

260. Sykora JL, Keleti G, Roche R, Volk DR, Kay GP, Burgess RA, Shapiro MA, Lippy EC: **Endotoxins, algae and *Limulus* amoebocyte lysate test in drinking water.** *Water Res* 1980, **14**(7):829-839.
261. Gerba CP, Goyal SM: **Potential for groundwater contamination by algal endotoxins.** In: *The water environment - Algal toxins and health.* Edited by Carmichael WW. New York: Plenum; 1981: 303-314.
262. Beasley VR, Cook WO, Dahlem AM, Hooser SB, Lovell RA, Valentine WM: **Algae intoxication in livestock and waterfowl.** *Vet Clin North Am Food Anim Pract* 1989, **5**(2):345-361.
263. Bagchi SN: **Cyanobacterial toxins.** *J Sci Ind Res (India)* 1996, **55**(8-9):715-727.
264. Tyagi MB, Thakur JK, Singh DP, Kumar A, Prasuna EG, Kumar A: **Cyanobacterial toxins: the current status.** *J Microbiol Biotechnol* 1999, **9**(1):9-21.
265. Mankiewicz J, Tarczynska M, Walter Z, Zalewski M: **Natural toxins from cyanobacteria.** *Acta Biol Cracov Ser Bot* 2003, **45**(2):9-20.
266. Codd GA, Morrison LF, Metcalf JS: **Cyanobacterial toxins: risk management for health protection.** *Toxicol Appl Pharmacol* 2005, **203**(3):264-272.
267. National Rivers Authority (NRA): **Toxic blue-green algae. Water Quality Series No. 2.** London: National Rivers Authority; 1990.
268. Drikas M: **Control and/or removal of algal toxins.** In: *Toxic cyanobacteria: current status of research and management.* Edited by Steffensen DA, Nicholson BC. Salisbury: Australian Centre for Water Quality Research; 1994: 93-101.
269. Yoo RS, Carmichael WW, Hoehn RC, Hruday SE: **Cyanobacterial (blue-green algal) toxins: A resource guide.** Denver: AWWA Research Foundation and American Water Works Association; 1995.
270. Codd GA, Ward CJ, Bell SG: **Cyanobacterial toxins: occurrence, modes of action, health effects and exposure routes.** *Arch Toxicol Suppl* 1997, **19**:399-410.
271. Pitois S, Jackson MH, Wood BJB: **Problems associated with the presence of cyanobacteria in recreational and drinking water.** *Int J Environ Health Res* 2000, **10**(3):203-218.
272. Queensland Water Quality Task Force: **Freshwater algal blooms in Queensland.** Brisbane: Queensland Water Quality Task Force; 1992.
273. Leder K, Sinclair MI, McNeil JJ: **Water and the environment: a natural resource or a limited luxury?** *Med J Aust* 2002, **177**(11-12):609-613.
274. Cooperative Research Centre for Water Quality and Treatment: **Blue green algae: a guide.**
[http://www.waterquality.crc.org.au/DWFacts/DWFact_Algae.pdf]
275. Johnstone P: **Guidelines for the recreational use of water potentially containing cyanobacteria. Occasional paper SWR No. 1.** Canberra: Subcommittee on Water Resources, Sustainable Land and Water Resources Management Committee, Agriculture and Resource Management Council of Australia and New Zealand; 1995.
276. Marshall I, Smith M, Neville G: **Health risk assessment and management of a cyanobacterial bloom affecting a non-municipal water supply.** *Environ Health* 2001, **1**(1):94-102.

277. Falconer IR: **Health implications of cyanobacterial (blue-green algal) toxins.** In: *Toxic cyanobacteria: current status of research and management.* Edited by Steffensen DA, Nicholson BC. Salisbury: Australian Centre for Water Quality Research; 1994: 61-65.
278. Falconer IR: **Toxic cyanobacterial bloom problems in Australian waters: risks and impacts on human health.** *Phycologia* 2001, **40**(3):228-233.
279. Codd GA, Bell SG, Brooks WP: **Cyanobacterial toxins in water.** *Water Sci Technol* 1989, **21**(3):1-13.
280. Chorus I: **Algal metabolites and water quality: Toxins, allergens, and taste-and-odor problems.** *Mem Ist Ital Idrobiol* 1993, **52**:570-572.
281. Fitzgerald DJ: **Cyanotoxins and human health - overview.** In: *Cyanotoxins - occurrence, causes, consequences.* Edited by Chorus I. Berlin: Springer-Verlag; 2001: 179-190.
282. Annadotter H, Cronberg G, Nyolo TO: **A malaria-like syndrome after baths and showers in cyanobacteria-contaminated water: the importance of lipopolysaccharide endotoxins [conference abstract].** In: *LV2000 – a new beginning – international conference: 2000; Jinja, Uganda.* [<http://www.inweh.unu.edu/lvfo/lv2000%20abstracts.htm>]
283. NSW Murray Regional Algal Coordinating Committee: **Blue-green algal bloom management.** 2002. [http://www.murraybluegreenalgae.com/detailed_biology.htm]
284. Mikheyskaya LV, Ovodova RG, Ovodov YS: **Isolation and characterization of lipopolysaccharides from cell walls of blue-green algae of the genus Phormidium.** *J Bacteriol* 1977, **130**(1):1-3.

Figure Legends:

FIGURE 1. Schematic of the basic LPS structure. The O-specific polysaccharide is the unit that is most exposed to the external environment and so manifests the greatest structural diversity; lipid A is the most conserved structure.

FIGURE 2. Primary lipid A structures: *E. coli* has a bis-phosphorylated diglucosamine backbone with six amide and ester linked fatty acyl chains. The non-endotoxic (and LPS-antagonist) *R. sphaeroides* lipid A has an identical disaccharide backbone but has five acyl residues, shorter ester-linked primary acyl chains and an unsaturated acyl group. *B. fragilis*, which expresses low endotoxic potential, has a mono-phosphorylated backbone and five acyl chains with longer chain lengths than those seen in *E. coli*. Lipid A from *Chromobacterium violaceum*, like *R. sphaeroides*, is an LPS antagonist. Figures adapted from: Weintraub *et al* [90], Rietschel *et al* [77] and Takayama & Qureshi [83].

Table 2. Cyanobacterial lipopolysaccharides and lethality

CYANOBACTERIUM	LETHALITY	REFERENCE
<i>Anacystis nidulans</i>	non-toxic at 10mg/kg**	[171]
<i>A. nidulans</i> KM	2.5mg/kg [†] (= approx. 800-fold greater than <i>Salmonella minnesota</i> LPS)	[160]
<i>Phormidium</i> spp. (x3)	all non-toxic at mean dose of 333mg/kg	[284]
<i>Schizothrix calcicola</i>	non-toxic at 200mg/kg	[167]
<i>Anabaena flos-aquae</i> UTEX 1444 <i>Anabaena cylindrica</i> UTEX 1611 <i>Oscillatoria brevis</i>	non-toxic at 250mg/kg LD ₅₀ 130mg/kg LD ₅₀ 190mg/kg	[168]
<i>Microcystis aeruginosa</i> 006 lipid A <i>M. aeruginosa</i> NRC-1 lipid A	LD ₅₀ approx 45mg/kg** LD ₅₀ 60mg/kg** LD ₅₀ 40mg/kg** LD ₅₀ approx 45mg/kg**	[158]
<i>Spirulina platensis</i> Lb 1475/4a	LD ₁₀₀ 425mg/kg**	[221]
<i>Microcystis</i> sp. PCC 7806	1 of 3 mice* died at 50µg/kg**	[159]
<i>M. aeruginosa</i> (bloom sample) <i>Cylindrospermopsis raciborskii</i> AWT 205	no deaths at 70mg/kg no deaths at 70mg/kg	[155]

*galactosamine-sensitised (=TNF-α hypersensitised)

† adrenalectomised mice

** assumed weight of mice: 20g

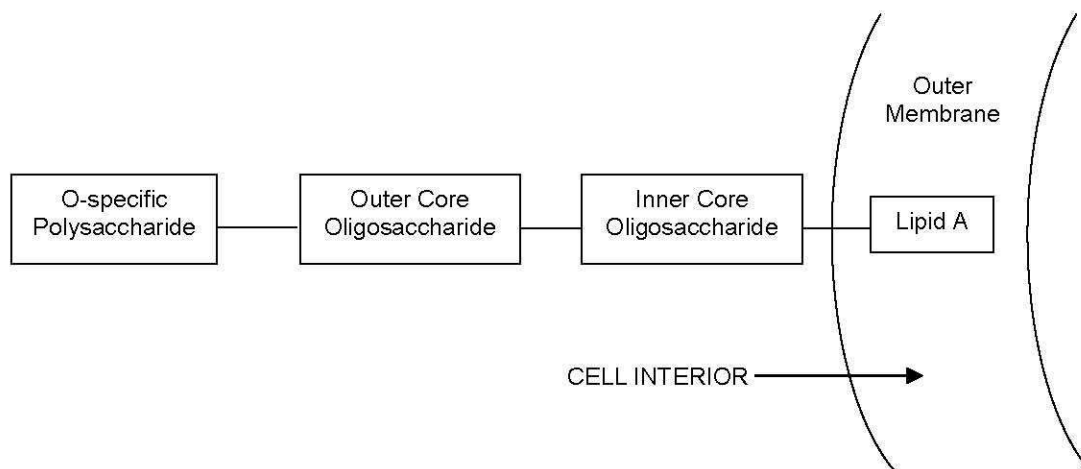

Figure 1

Additional files provided with this submission:

Additional file 1 : Table 1.doc : 60Kb

<http://www.ehjournal.net/imedia/1224303562854813/sup1.DOC>